

# Manufacturing Processes: Theory Of Metal Cutting & Machine Tool

**Dr. Dwi Rahdiyanta**

**Jurusan Pendidikan Teknik Mesin  
FT-UNY**

# Introduction to Manufacturing Processes

- **Definition of Manufacturing**
- The word manufacturing is derived from Latin:  
*manus = hand, factus = made*
- Manufacturing is the economic term for making goods and services available to satisfy human wants.
- *Manufacturing implies creating value to a raw material by applying useful mental and physical labour.*
- Whether from nature or industry materials cannot be used in their raw forms for any useful purpose.
- The materials are then shaped and formed into different useful components through different manufacturing processes to fulfil the needs of day-to-day work.
- *Manufacturing converts the raw materials to finished products to be used for some purpose.*

# Manufacturing Processes

- Manufacturing processes is a very fundamental subject since it is of interest not only to mechanical engineers but also to engineers from other discipline of engineering.
- There are various manufacturing processes by which a product can be made.
- Each process however has its own limitation and restriction and due to this reason a particular process is adopted to certain specific applications.
- Thus while a product can be manufactured by two or more processes, the real problem is to select the most economical out of them.
- A detailed understanding of various manufacturing processes is thus very essential for every engineer. This helps in designing the proper product required for him.
- He would be able to assess the feasibility of manufacturing from his designs.
- He may find that there are more than one process is available for manufacturing a particular product and he can make a proper choice of the process which would require lowest manufacturing cost.

# CLASSIFICATION OF MANUFACTURING PROCESSES

Manufacturing processes can be grouped as:

- Casting, foundry or moulding processes.
- Forming or metal working processes.
- Machining (metal removal) processes.
- Joining and assembly
- Surface treatments (finishing).
- Heat treating

These groups are not mutually exclusive. For example, some finishing processes involve a small amount of metal removal or metal forming. A laser can be used for joining/metal removal/heat treating.

# CLASSIFICATION OF MANUFACTURING PROCESSES

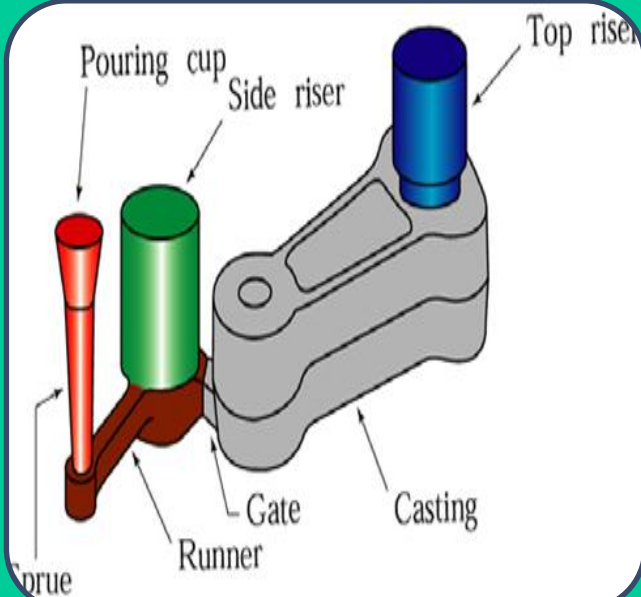

## Casting, foundry or moulding processes

- Sand casting
- Investment casting
- Die casting
- Centrifugal Casting
- Continuous Casting

# CLASSIFICATION OF MANUFACTURING PROCESSES

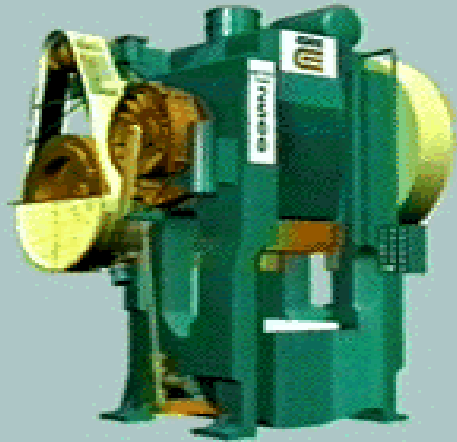

## Forming or metal working processes

- **Rolling**
- **Forging**
- **Extrusion**
- **Drawing**
- **Sheet metal works**

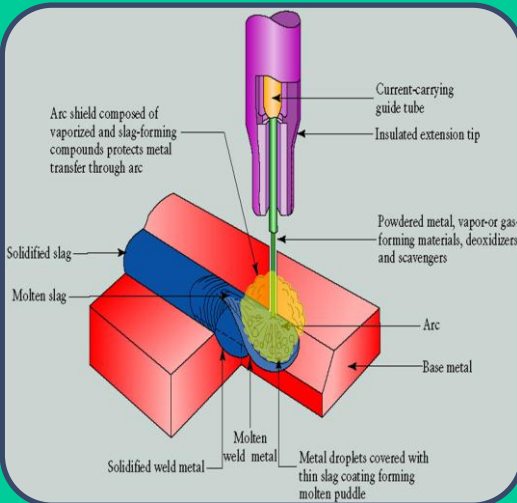

## Joining processes

- **Welding (SMAW, TIG, MIG, PLASMA, LBW, EBW etc.)**
- **Soldering**
- **Brazing**
- **Adhesive bonding**
- **Riveting**

# CLASSIFICATION OF MANUFACTURING PROCESSES

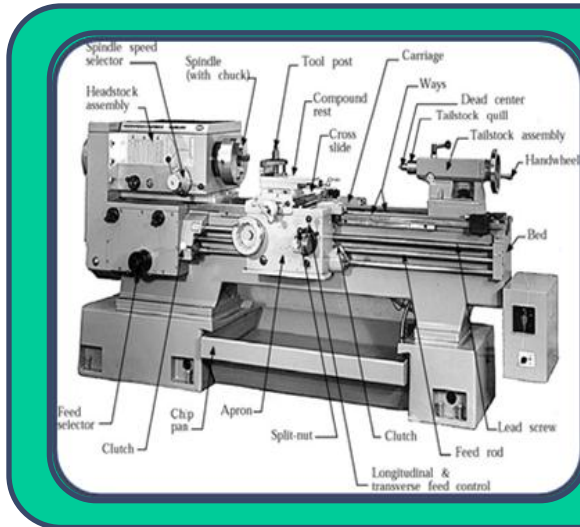

## Conventional Machining processes

- **Turning**
- **Milling**
- **Drilling**
- **Shaping**
- **Grinding**
- **Broaching**

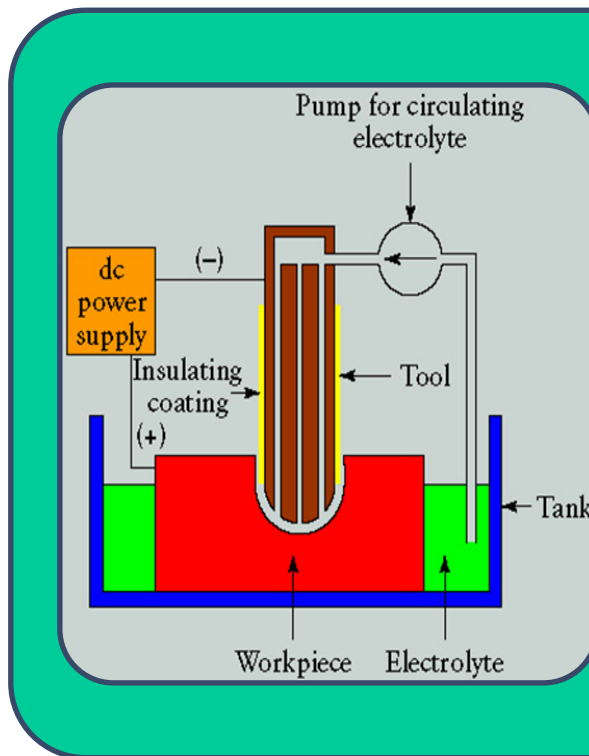

## Nonconventional Machining processes

- **Electro chemical Machining (ECM)**
- **Electro Discharge Machining (EDM)**
- **Wire Electro Discharge Machining (WEDM)**
- **Abrasive Jet Machining (AJM)**
- **Ultrasonic Machining (USM)**
- **Liquid Jet Machining (LJM)**
- **Electron Beam Machining (EBM)**
- **Laser Beam Machining (LBM)**
- **Ion Beam Machining (IBM)**
- **Plasma Arc Machining (PAM)**

# Manufacturing Processes and Manufacturing system

- **Manufacturing system:**

- A collection of operations and processes used to obtain a desired product(s) or component(s) is called a manufacturing system.
- *The manufacturing system is therefore the design or arrangement of the manufacturing processes..*

- **Production system:**

- *A production system includes people, money, equipment, materials and supplies, markets, management and the manufacturing system.*





# Application of Manufacturing Processes



# Application of Manufacturing Processes





# Application of Manufacturing Processes



# Application of Manufacturing Processes

The "Columbus" carrying the Enterprise space shuttle





# Application of Manufacturing Processes

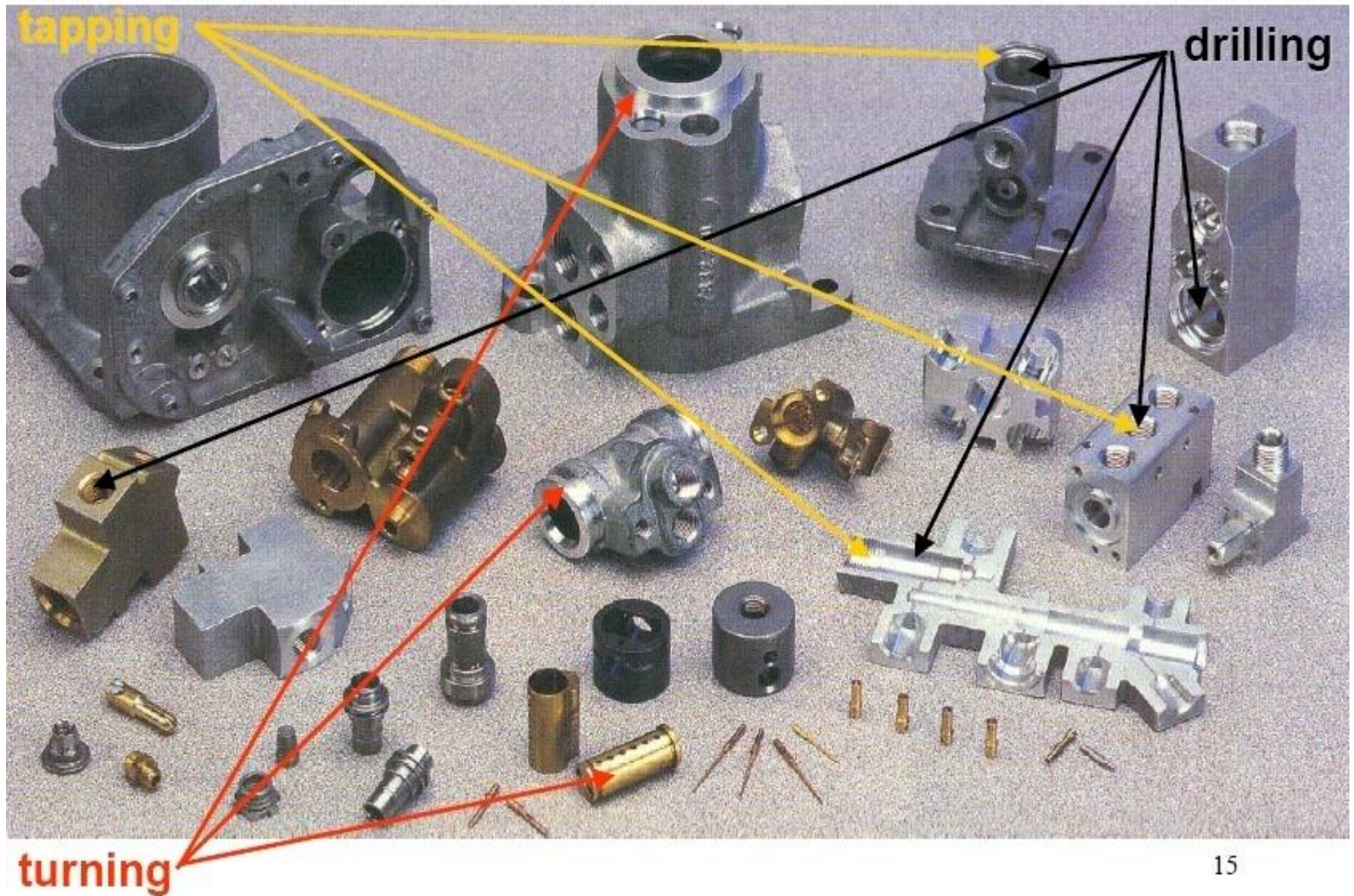



# Application of Manufacturing Processes (Gears)

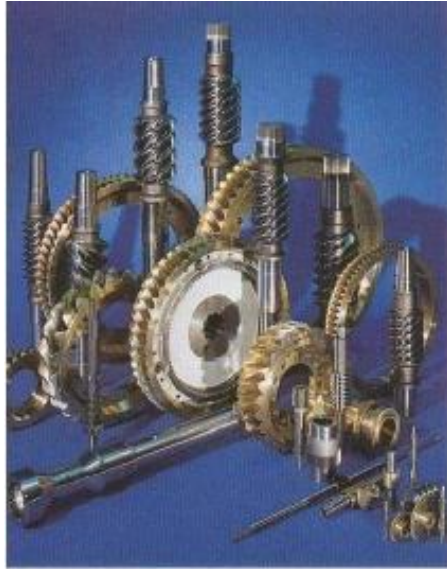

# Diagrammatic Representation of Material Removal Operations

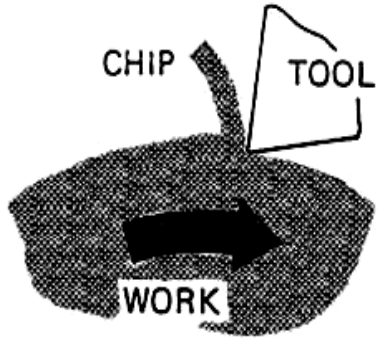

LATHE TURNING

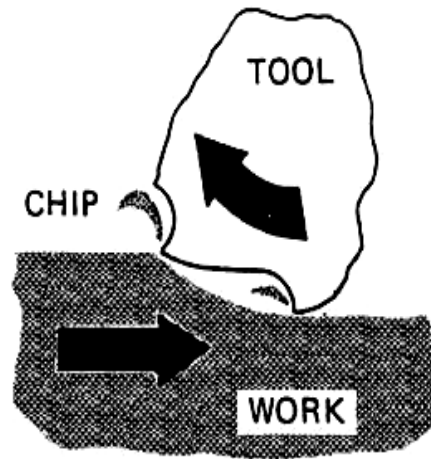

MILLING

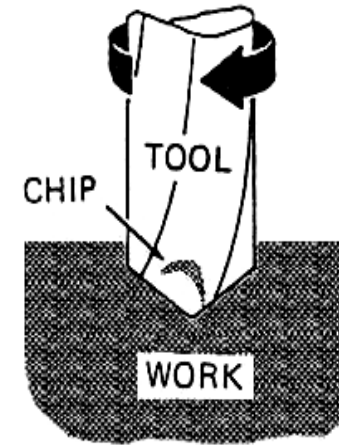

DRILLING

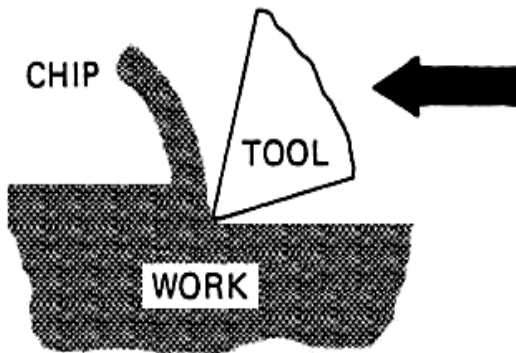

SHAPER

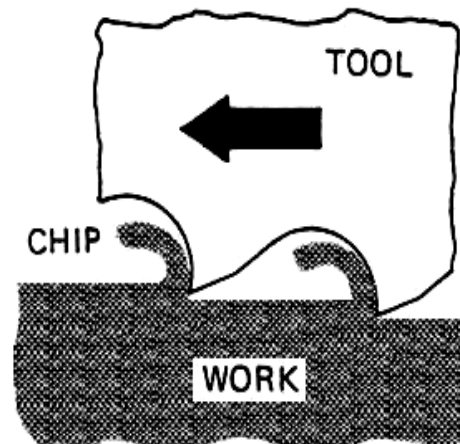

BROACHING

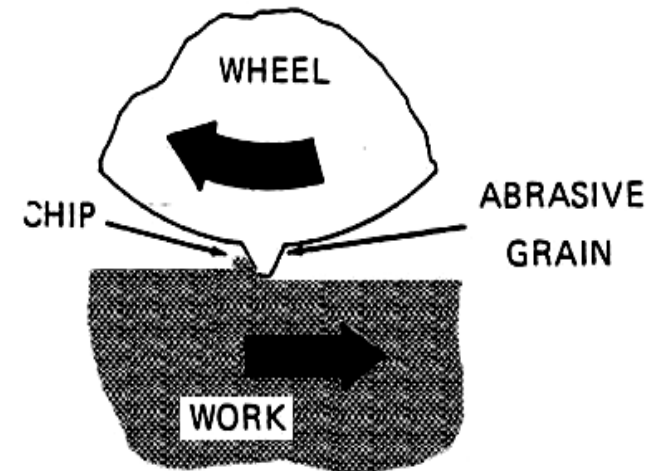

GRINDING



# Examples of cutting processes

(a) Straight turning

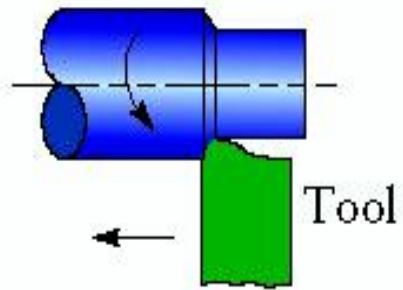

(b) Cutting off

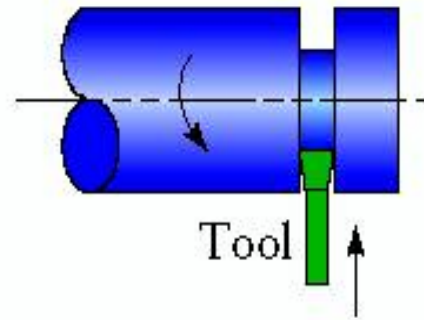

(c) Slab milling

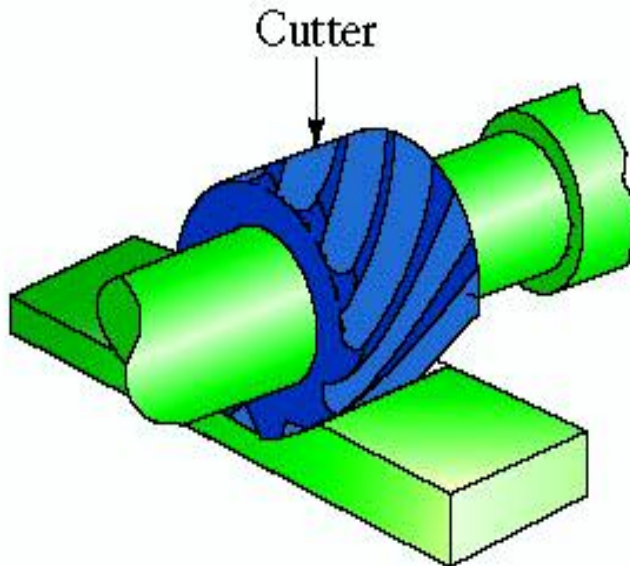

(d) End milling

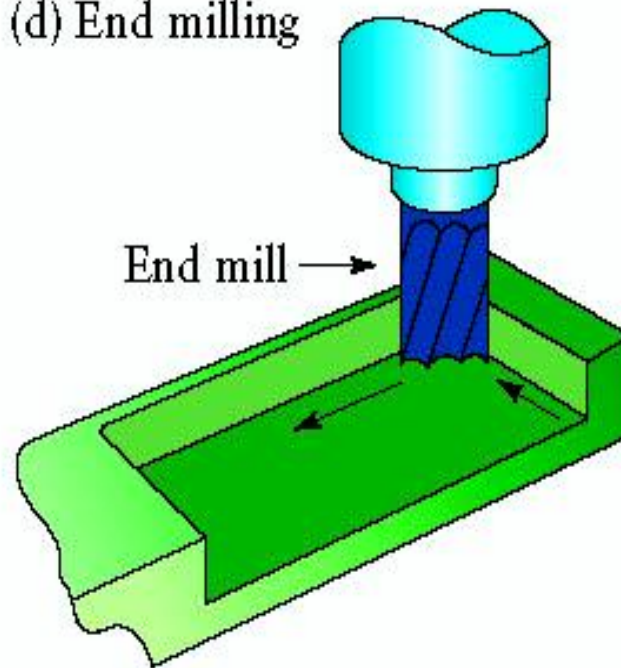

Source: "Manufacturing Processes for Engineering Materials", 4<sup>th</sup> edition, Kalpakjian, Schmid, Prentice Hall 2003

# An Introductory video on Manufacturing Processes



# Machine Tools

Machine tools are kind of machines on which metal cutting or metal forming processes are carried out.

Material removal is essentially done on machine tools, which may be Lathe, Milling, Drilling, Shaping, Planing, Broaching and Grinding machines.

The functions of machine tools are:

- holding the workpiece
- holding the tool
- moving the tool or the work piece or both relative to each other,
- supply energy required to cause metal cutting.

Every machine tool has a primary cutting tool for metal removal.

# Machining Parameters

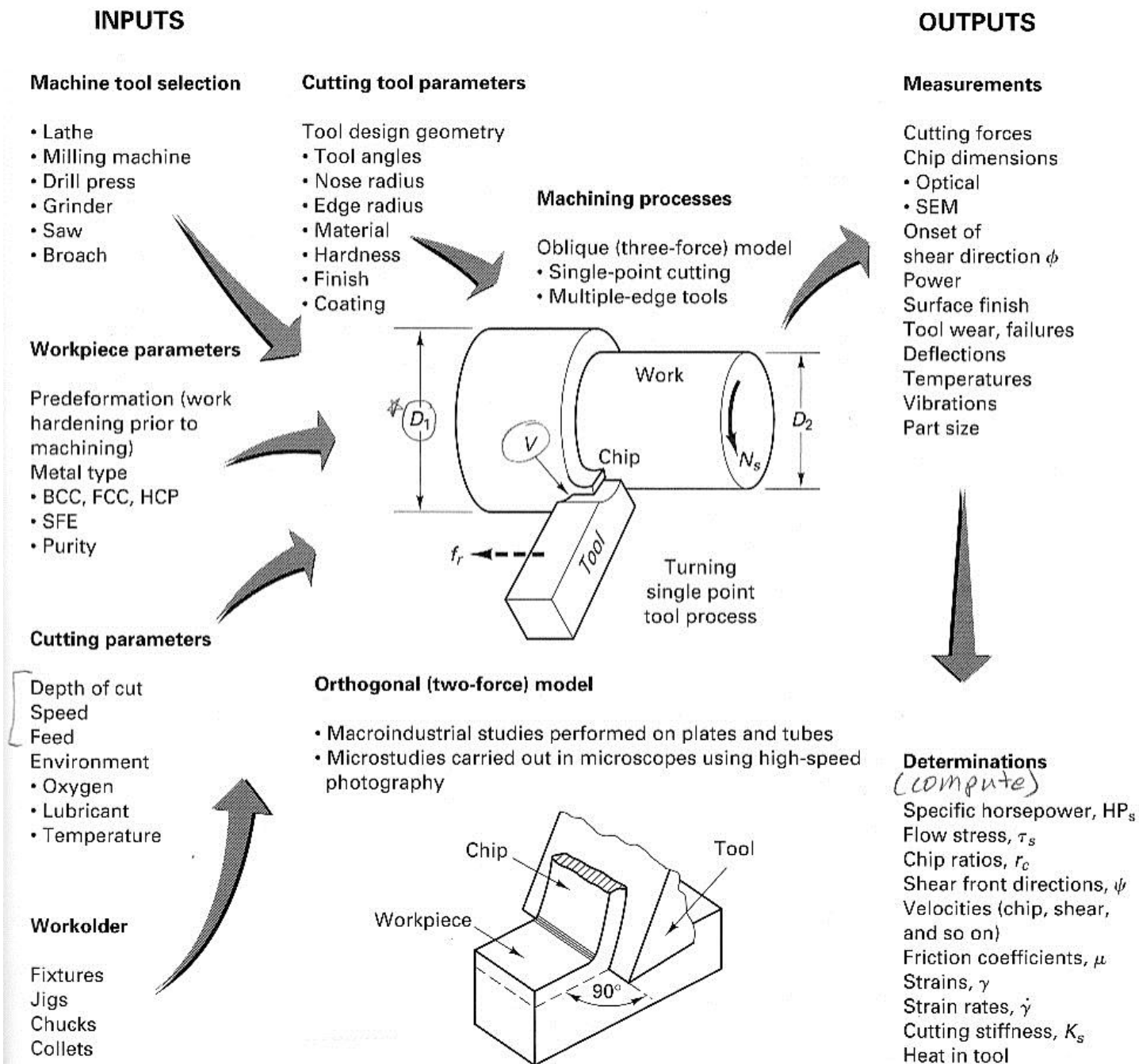

**FIGURE 21-1** The fundamental inputs and outputs to machining processes.

# Cutting Parameter Relationships



# Cutting Parameters

**Cutting Speed:** Cutting speed is the distance traveled by the work surface in unit time with reference to the cutting edge of the tool.

The cutting speed,  $v$  is simply referred to as speed and usually expressed in m/min.

**Feed:** The feed is the distance advanced by the tool into or along the workpiece each time the tool point passes a certain position in its travel over the surface.

In case of turning, feed is the distance that the tool advances in one revolution of the workpiece.

Feed  $f$  is usually expressed in mm/rev. Sometimes it is also expressed in mm/min and is called feed rate.

**Depth of cut :** It is the distance through which the cutting tool is plunged into the workpiece surface.

Thus it is the distance measured perpendicularly between the machined surface and the unmachined (uncut) surface or the previously machined surface of the workpiece.

The depth of cut  $d$  is expressed in mm.

# Selection of cutting speed and feed

- **The selection of cutting speed and feed is based on the following parameters:**
  - **Workpiece material**
  - **Tool Material**
  - **Tool geometry and dimensions**
  - **Size of chip cross-section**
  - **Types of finish desired**
  - **Rigidity of the machine**
  - **Types of coolant used**





# Selection of cutting speed and feed

## Approximate Ranges of Recommended Cutting Speeds Turning Operations

WORKPIECE MATERIAL	CUTTING SPEED
	m/min
Aluminum alloys	200–1000
Cast iron, gray	60–900
Copper alloys	50–700
High-temperature alloys	20–400
Steels	50–500
Stainless steels	50–300
Thermoplastics and thermosets	90–240
Titanium alloys	10–100
Tungsten alloys	60–150

Note: (a) The speeds given in this table are for carbides and ceramic cutting tools.



# Cutting tools & its characteristics

Cutting tool is a device, used to remove the unwanted material from given workpiece. For carrying out the machining process, cutting tool is fundamental and essential requirement. **A cutting tool must have the following characteristics:**

- **Hardness:** The tool material must be harder than the work piece material. Higher the hardness, easier it is for the tool to penetrate the work material.
- **Hot hardness:** Hot Hardness is the ability of the cutting tool must to maintain its Hardness and strength at elevated temperatures. This property is more important when the tool is used at higher cutting speeds, for increased productivity.
- **Toughness:** In spite of the tool being tough, it should have enough toughness to withstand the impact loads that come in the start of the cut to force fluctuations due to imperfections in the work material. Toughness of cutting tools is needed so that tools don't chip or fracture, especially during interrupted cutting operations like milling.

# Cutting tools & its characteristics

- **Wear Resistance:** The tool-chip and chip-work interface are exposed to severe conditions that adhesive and abrasion wear is very common. Wear resistance means the attainment of acceptable tool life before tools need to be replaced.
- **Low friction:** The coefficient of friction between the tool and chip should be low. This would lower wear rates and allow better chip flow.
- **Thermal characteristics:** Since a lot of heat is generated at the cutting zone, the tool material should have higher thermal conductivity to dissipate the heat in shortest possible time, otherwise the tool temperature would become high, reducing its life.

# Cutting Tool Materials

- **Carbon and Medium alloy steels** : These are the oldest of the tool materials dating back hundreds of years. In simple terms it is a high carbon steel (steel which contains about 0.9 to 1.3% carbon). Inexpensive, easily shaped, sharpened. No sufficient hardness and wear resistance. Limited to low cutting speed operation
- **High Speed Steel (1900)**: The major difference between high speed tool steel and plain high carbon steel is the addition of alloying elements ([manganese, chromium, tungsten, vanadium, molybdenum, cobalt, and niobium](#)) to harden and strengthen the steel and make it more resistant to heat (hot hardness). They are of two types: [Tungsten HSS \(denoted by T\), Molybdenum HSS \(denoted by M\)](#).
- **Cemented Carbides or Sintered Carbides (1926-30)**: These tools are produced by powder metallurgy. Carbide tools are basically of three types: tungsten carbide (WC), tantalum carbide (TaC), and titanium carbide (TiC). The carbides or combined carbides are mixed with a binder of cobalt. [They are able to retain hardness to a temperature of about 1000<sup>0</sup>C. So they can be used at high speeds.](#) Carbide tool are available as brazed tip tools (carbide tip is brazed to steel tool) and inserts (inserts are of various shapes- triangular, square diamond and round).

# Typical carbide inserts

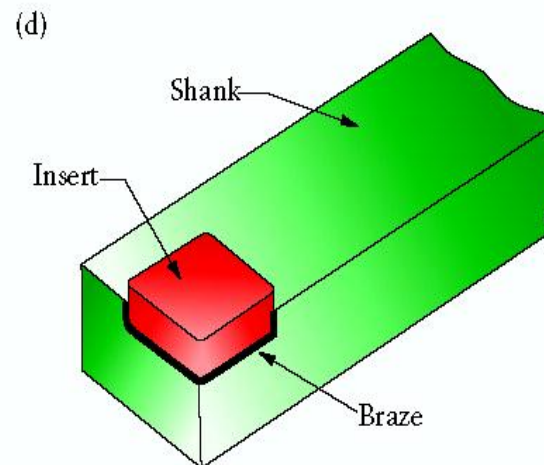
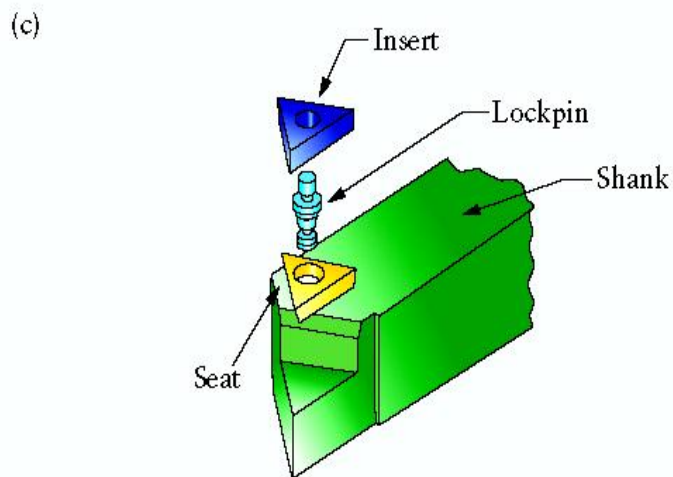
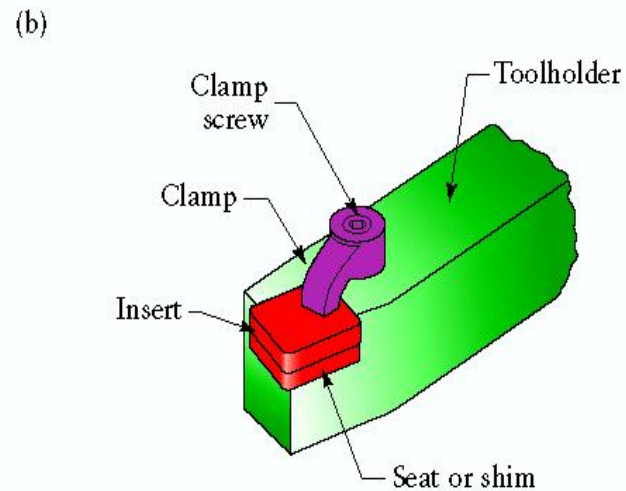
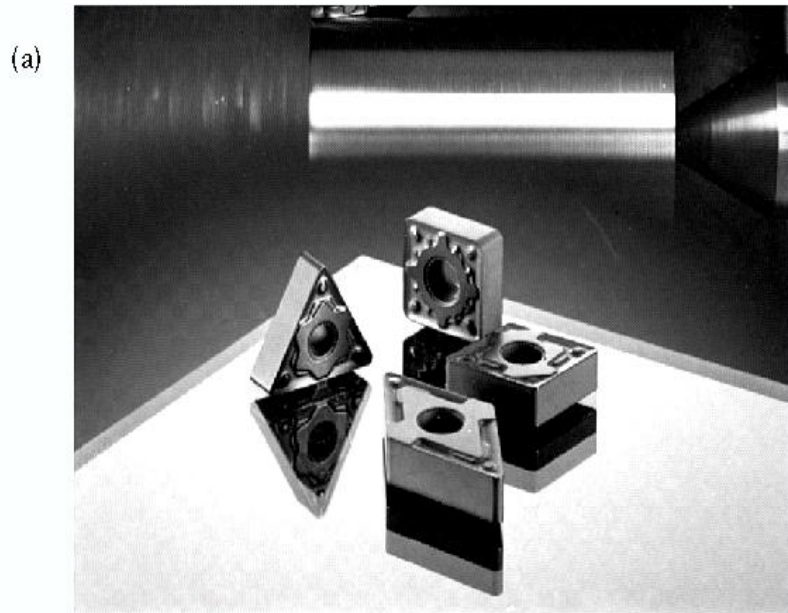

FIGURE: (a) Typical carbide inserts with various shapes and chip-breaker features. Round inserts are also available. The holes in the inserts are standardized for interchangeability. *Source:* Courtesy of Kyocera Engineered Ceramics, Inc., and *Manufacturing Engineering*, Society of Manufacturing Engineers. (b) Methods of attaching inserts to a tool shank by clamping, (c) with wing lockpins, and (d) with a brazed insert on a shank

# Cutting Tool Materials

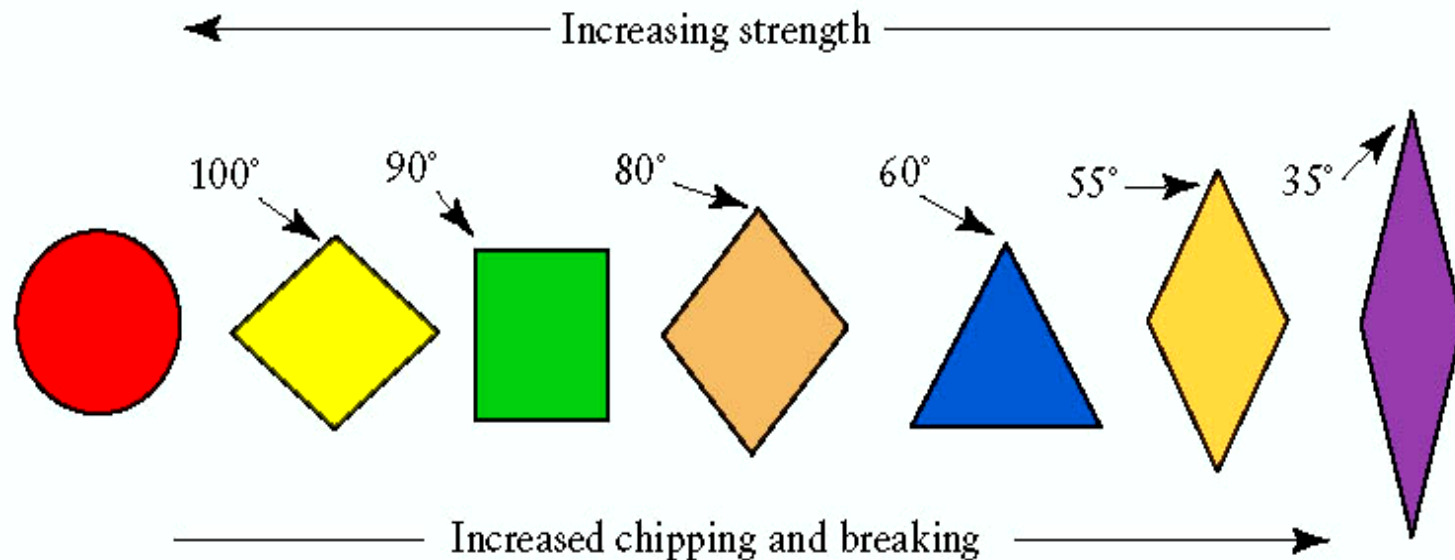
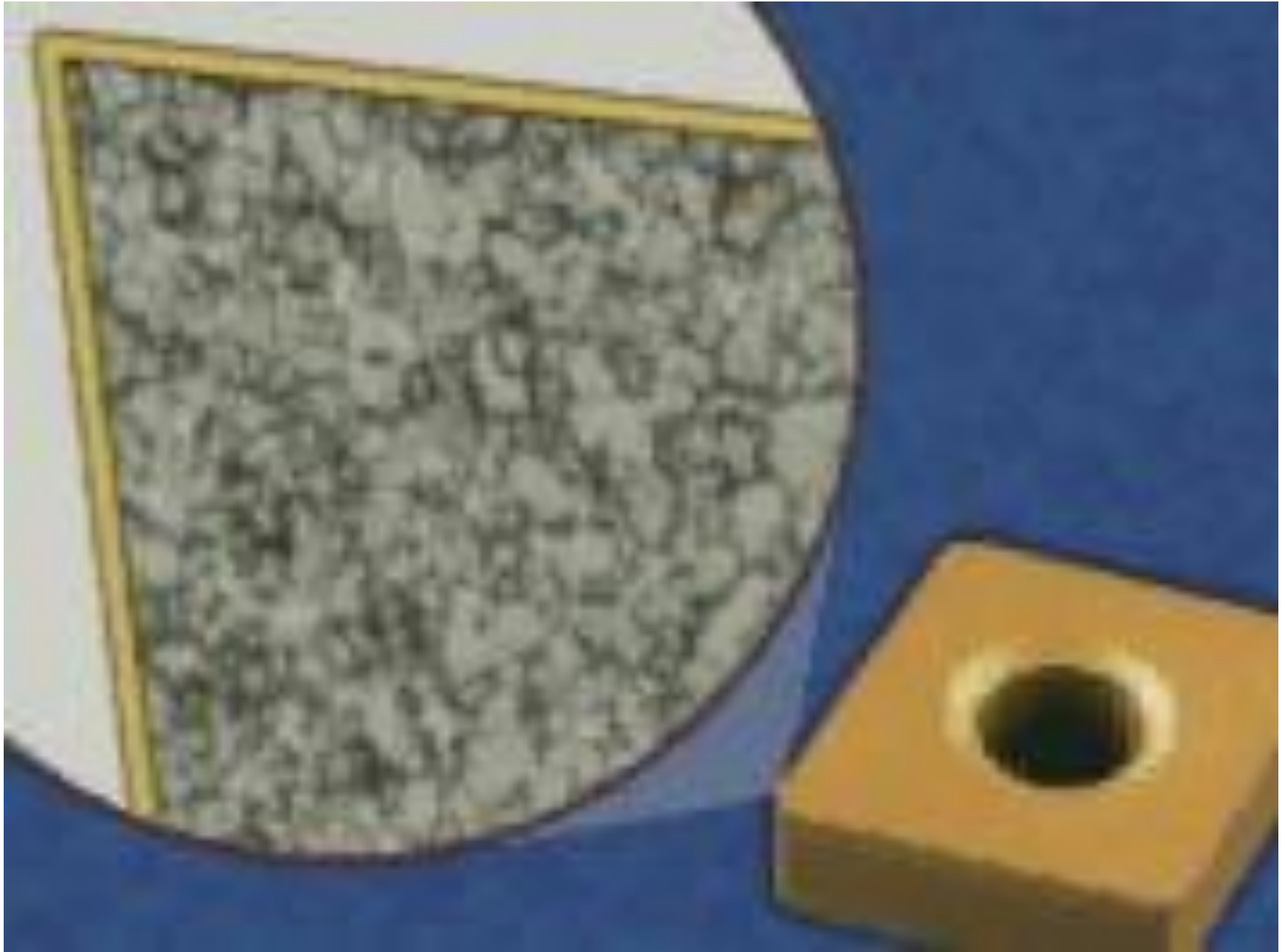

FIGURE: Relative edge strength and tendency for chipping and breaking of inserts with various shapes. Strength refers to that of the cutting edge shown by the included angles. *Source:* Kennametal, Inc.





# Cutting Tool Materials



# Cutting Tool Materials

## Factors affecting choice of insert shape

	R	90	80	80	60	55	35	
Roughing (strength)	●	●	●	○	○			
Light roughing/Semi-finishing (No. of edges)		○	●	●	●	●	●	
Finishing (No. of edges)			○	○	●	●	●	
Turning and Facing (feed directions)			●	○	○	●	●	
Profiling (Accessibility)			○	○	○	●	●	
Operational versatility	○		●	○	○	●	○	
Limited machine power			○	○	●	●	●	
Vibration tendencies (reduction)				○	●	●	●	
Hard material	●	●						
Intermittent Machining	●	●	○	○	○			
Large entering angle			●	●	●	●	●	
Small entering angle	●	●		●	●			

● Most suitable

○ Suitable

# Cutting Tool Materials

Carbides are now so popular that ISO has developed an application chart.

The chart is divided into three main areas: ISO - P, M and K.

**ISO P:** is for the machining of long chip formation materials.

**ISO M:** is for the machining of difficult to machine materials such as austenitic stainless steel.

**ISO K:** is for the machining of short chip formation materials such as cast iron, hardened steel.

Range of materials	Typical Machining Operations	Demands on the grade
<b>P</b> Steel, cast steel, stainless steel, long chipping malleable iron.	<b>01</b> Extreme finishing to high surface finish.	High wear resistance. ↑ ↓ Good toughness and edge strength.
	<b>05</b>	
	<b>10</b> Finishing at high cutting speed.	
	<b>15</b>	
	<b>20</b> Copy turning operations.	
	<b>25</b>	
	<b>30</b> Rough turning and turning with low cutting speeds.	
<b>M</b> Steel, cast steel, manganese steel, alloy cast iron, austenitic stainless steel castings, malleable iron, free-cutting steel.	<b>35</b>	High wear resistance. ↑ ↓ Good toughness and edge strength.
	<b>40</b> Heavy roughing and intermittent machining.	
	<b>45</b>	
	<b>50</b>	
<b>K</b> Cast iron, chilled cast iron, short chipping malleable iron, hardened steel, non-ferrous metals, plastics, wood.	<b>10</b> Finishing at high cutting data	High wear resistance. ↑ ↓ Good toughness and edge strength.
	<b>20</b> Finishing at low cutting data	
	<b>30</b>	
	<b>40</b> Heavy roughing and intermittent machining.	
	<b>01</b> Finishing to high surface finish.	
	<b>05</b>	
	<b>10</b> Semi-finishing to light roughing.	
<b>15</b>		
<b>20</b> Heavy roughing and intermittent machining.		
<b>25</b>		
<b>30</b> Machining at low cutting data.		



# Cutting Tool Materials

- **Coated cemented carbide (1960):** Tool life to about 200 to 300 % or more. A thin, chemically stable, hard refractory coating of TiC, TiN or  $Al_2O_3$  is used. The bulk of the tool is tough, shock resistant carbide that can withstand high temperatures. **Because of its wear resistance, coated tool can be used at still higher speeds.**
- **Cast cobalt alloys or Stellites (1915):** It is a non-ferrous alloy consisting mainly of cobalt, tungsten and chromium (38% to 53% Cobalt, 30% to 33% Chromium, and 4% to 20% Tungsten). Other elements added in varying proportions are molybdenum, manganese, silicon and carbon. It has good shock and wear resistance properties and retains its hardness up to  $900^{\circ}C$ . Stellite tools can operate at speed about 25% higher than that of HSS tools .
- **Cemented oxides or Ceramic Cutting Tools (1950s):** Non-metallic materials made of pure Aluminum oxide by powder metallurgy. The application ceramic cutting tools are limited because of their extreme brittleness. The transverse rupture strength (TRS) is very low. This means that they will fracture more easily when making heavy interrupted cuts. However, the strength of ceramics under compression is much higher than HSS and carbide tools. **It has high hot hardness (up to 1200 degree C), so capable of running at high speeds.**

# Cutting Tool Materials

- **Cermets:** Cermets are ceramic material in metal binders. TiC, nickel, TiN, and other carbides are used as binders. Cermets have higher hot hardness and oxidation resistance than cemented carbides but less toughness. They are used for finishing operation. The main problem with cermets is that due to thermal shock the inserts crack.
- **Diamond:** They are of two types - industrial grade natural diamonds, and synthetic polycrystalline diamonds. Because diamonds are pure carbon, they have an affinity for the carbon of ferrous metals. Therefore, they can only be used on non-ferrous metals. Feeds should be very light and high speeds Rigidity in the machine tool and the setup is very critical because of the extreme hardness and brittleness of diamond.
- **Cubic Boron Nitride (1962):** Cubic boron nitride (CBN) is similar to diamond in its polycrystalline structure and is also bonded to a carbide base. With the exception of titanium, or titanium-alloyed materials, CBN will work effectively as a cutting tool on most common work materials. However, the use of CBN should be reserved for very hard and difficult-to-machine materials.

# Properties of Cutting Tool Materials

PROPERTY	CARBIDES				CERAMICS	CUBIC BORON NITRIDE	SINGLE-CRYSTAL DIAMOND*
	HIGH-SPEED STEEL	CAST ALLOYS	WC	TiC			
Hardness	83-86 HRA	82-84 HRA 46-62 HRC	90-95 HRA 1800-2400 HK	91-93 HRA 1800-3200 HK	91-95 HRA 2000-3000 HK	4000-5000 HK	7000-8000 HK
Compressive strength MPa psi x 10 <sup>3</sup>	4100-4500 600-650	1500-2300 220-335	4100-5850 600-850	3100-3850 450-560	2750-4500 400-650	6900 1000	6900 1000
Transverse rupture strength MPa psi x 10 <sup>3</sup>	2400-4800 350-700	1380-2050 200-300	1050-2600 150-375	1380-1900 200-275	345-950 50-135	700 105	1350 200
Impact strength J in.-lb	1.35-8 12-70	0.34-1.25 3-11	0.34-1.35 3-12	0.79-1.24 7-11	< 0.1 < 1	< 0.5 < 5	< 0.2 < 2
Modulus of elasticity GPa psi x 10 <sup>5</sup>	200 30	- -	520-690 75-100	310-450 45-65	310-410 45-60	850 125	820-1050 120-150
Density kg/m <sup>3</sup> lb/in <sup>3</sup>	8600 0.31	8000-8700 0.29-0.31	10,000- 15,000 0.36-0.54	5500-5800 0.2-0.22	4000-4500 0.14-0.16	3500 0.13	3500 0.13
Volume of hard phase (%)	7-15	10-20	70-90	-	100	95	95
Melting or decomposition temperature °C °F	1300 2370	- -	1400 2550	1400 2550	2000 3600	1300 2400	700 1300
Thermal conductivity, W/mK	30-50	-	42-125	17	29	13	500-2000
Coefficient of thermal expansion, x 10 <sup>-6</sup> /°C	12	-	4-6.5	7.5-9	6-8.5	4.8	1.5-4.8

\* The values for polycrystalline diamond are generally lower, except impact strength, which is higher.

Source "Manufacturing Processes for Engineering Materials", 4<sup>th</sup> edition, Kalpakjian, Schmid, Prentice Hall 2003

# Cutting tool material and recommended speed range:

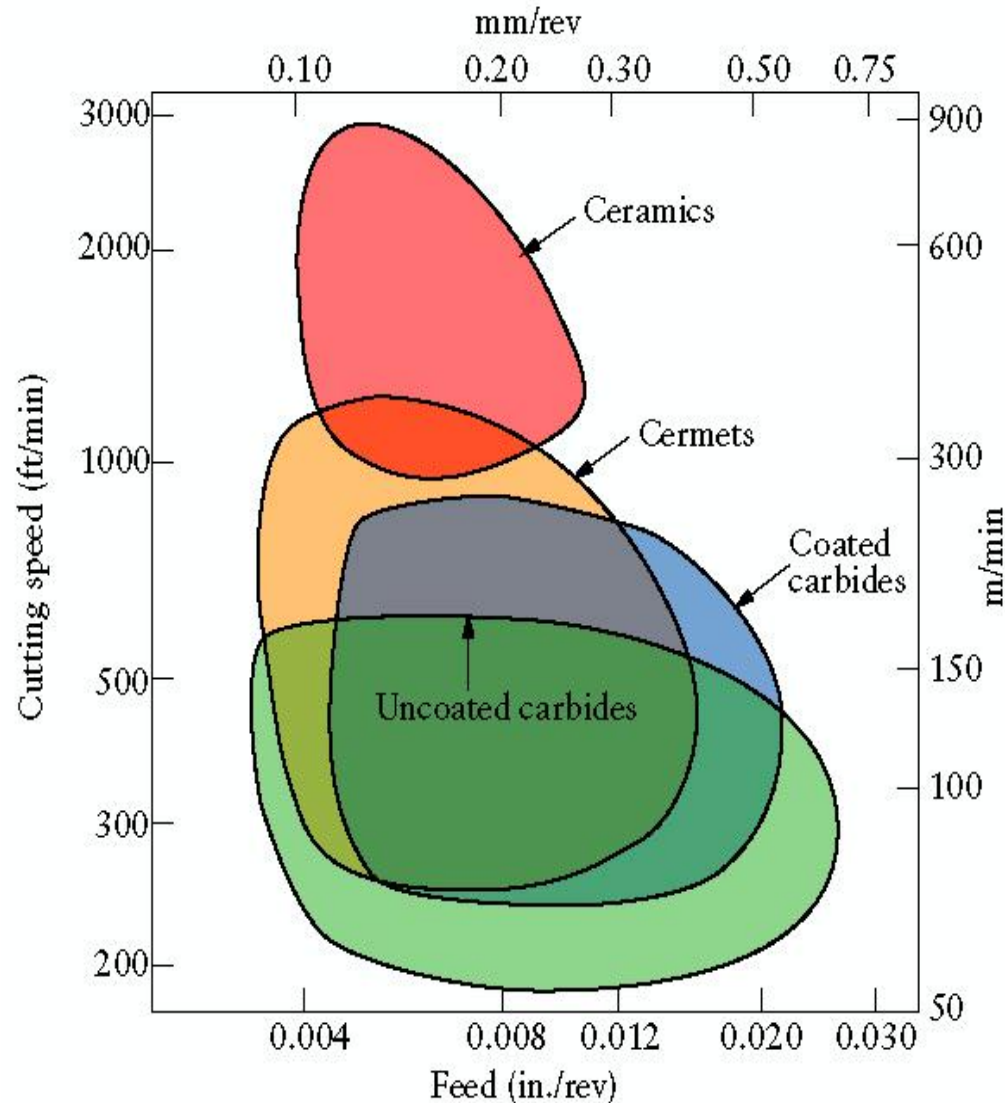
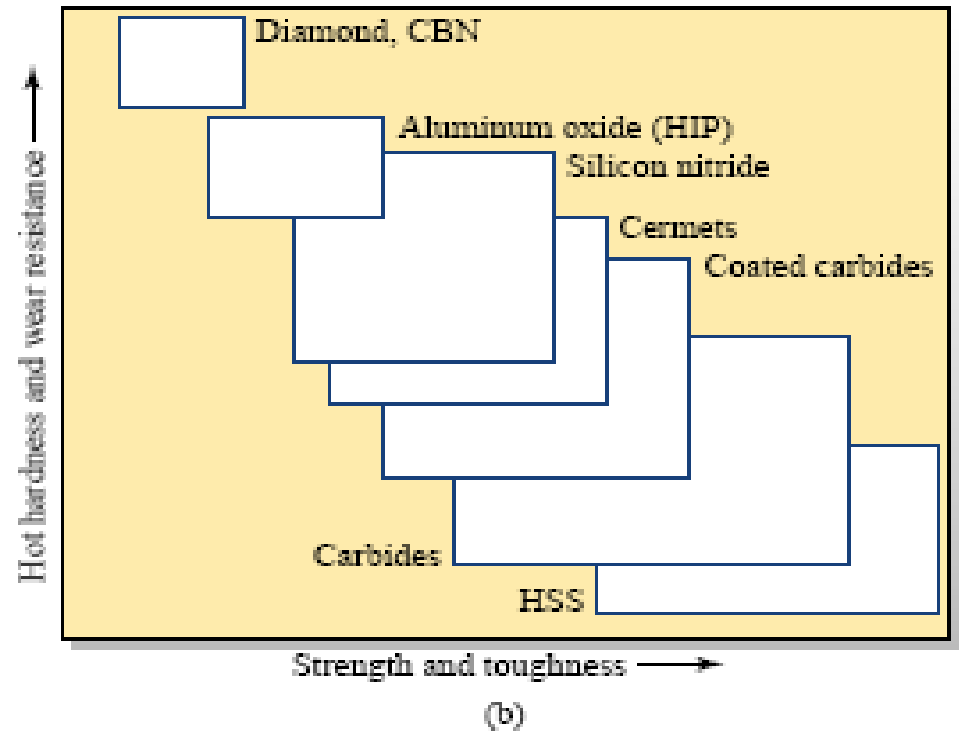
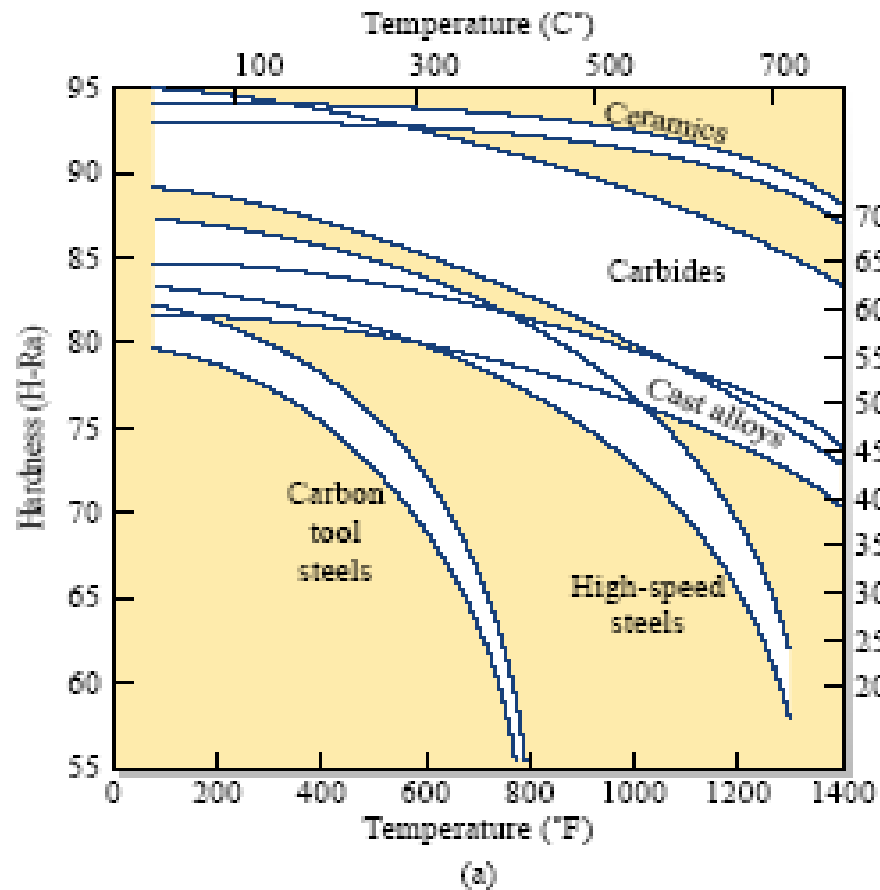

FIGURE : The range of applicable cutting speeds and fees for a variety of tool materials.  
*Source:* Valenite, Inc.

Figure from: “ Manufacturing Processes for Engineering Materials”, 4<sup>th</sup> edition, Kalpakjian, Schmid, Prentice Hall 2003

# Cutting tool materials hardness and strength



**(a) Hardness of various cutting-tool materials as a function of temperature. (b) Ranges of properties of various groups of materials.**

Source: **George Schneider, Jr. CMfgE**, Cutting Tool Applications

# Operating Characteristics of Cutting tool materials

## Operating Characteristics of Cutting-Tool Materials

Tool materials	General characteristics	Modes of tool wear or failure	Limitations
High-speed steels	High toughness, resistance to fracture, wide range of roughing and finishing cuts, good for interrupted cuts	Flank wear, crater wear	Low hot hardness, limited hardenability, and limited wear resistance
Uncoated carbides	High hardness over a wide range of temperatures, toughness, wear resistance, versatile and wide range of applications	Flank wear, crater wear	Cannot use at low speed because of cold welding of chips and microchipping
Coated carbides	Improved wear resistance over uncoated carbides, better frictional and thermal properties	Flank wear, crater wear	Cannot use at low speed because of cold welding of chips and microchipping
Ceramics	High hardness at elevated temperatures, high abrasive wear resistance	Depth-of-cut line notching, microchipping, gross fracture	Low strength, low thermo-mechanical fatigue strength
Polycrystalline cubic boron nitride (cBN)	High hot hardness, toughness, cutting-edge strength	Depth-of-cut line notching, chipping, oxidation, graphitization	Low strength, low chemical stability at higher temperature
Polycrystalline diamond	Hardness and toughness, abrasive wear resistance	Chipping, oxidation, graphitization	Low strength, low chemical stability at higher temperature

# Single Point Cutting Tool Geometry

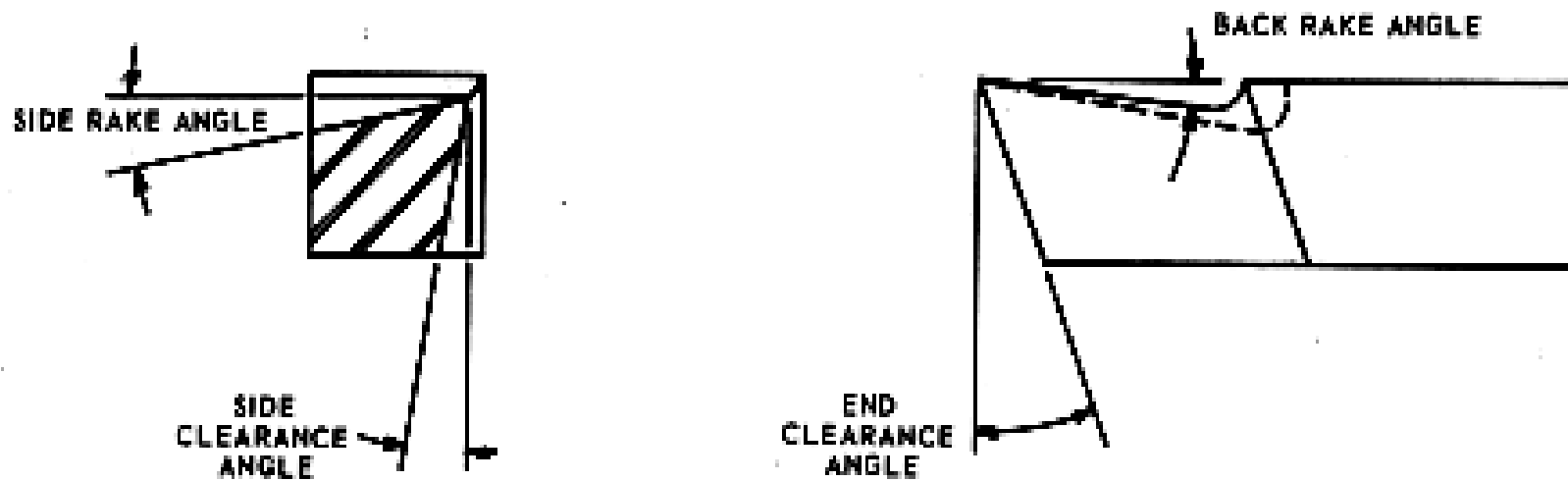
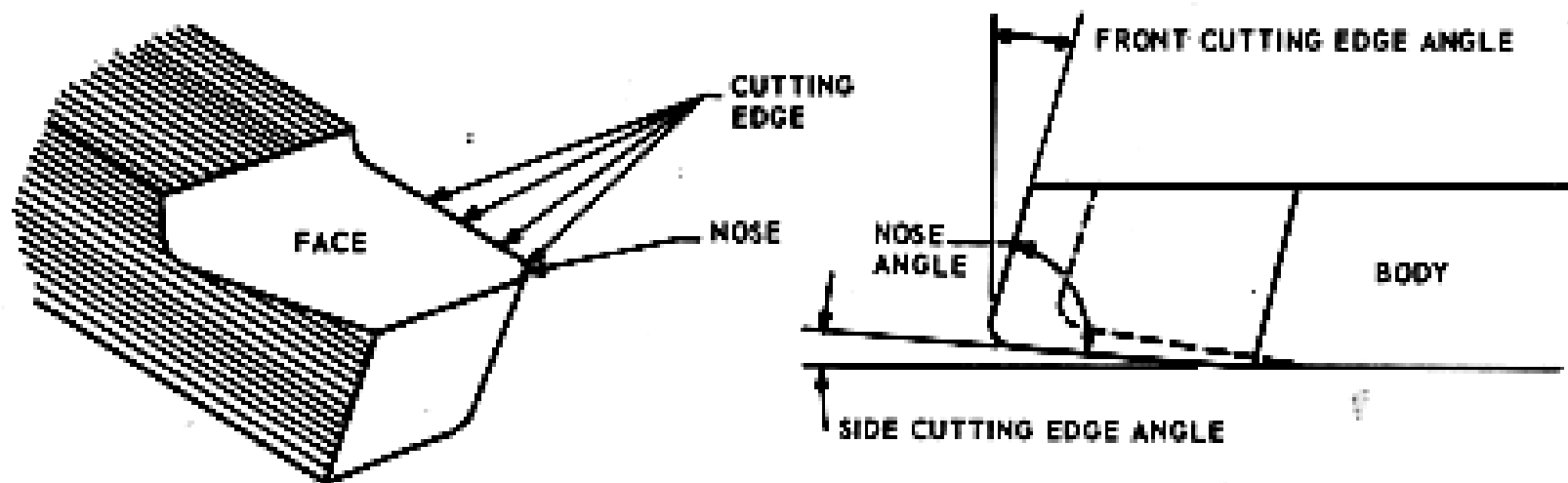

# Right hand single point cutting tool

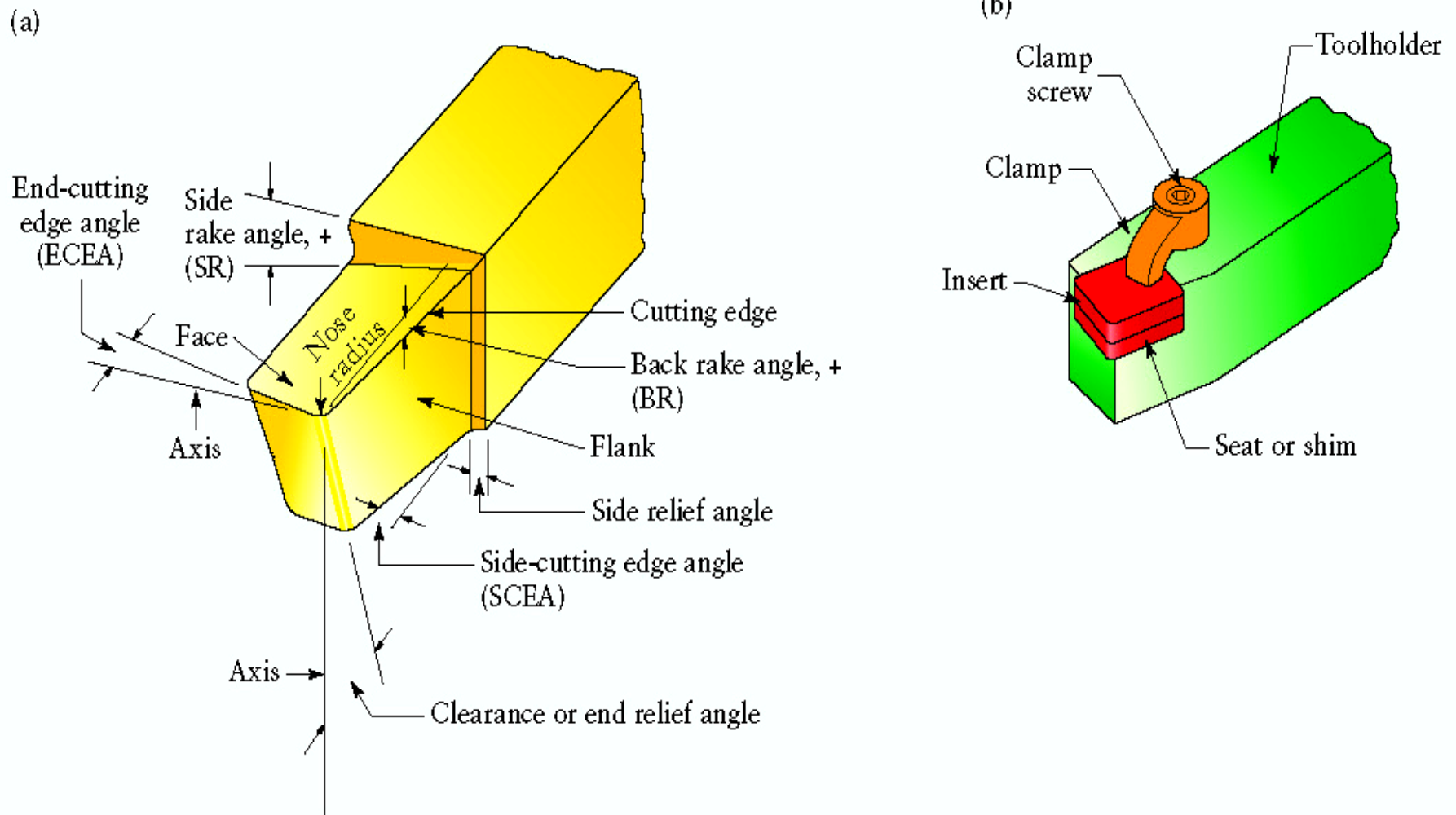

FIGURE : (a) Schematic illustration of a right-hand cutting tool. Although these tools have traditionally been produced from solid tool-steel bars, they have been largely replaced by carbide or other inserts of various shapes and sizes, as shown in (b).

Source: “ Manufacturing Processes for Engineering Materials”, 4<sup>th</sup> edition, Kalpakjian, Schmid, Prentice Hall 2003



# Single Point Cutting Tool Geometry

## Geometry of positive rake single point cutting tool

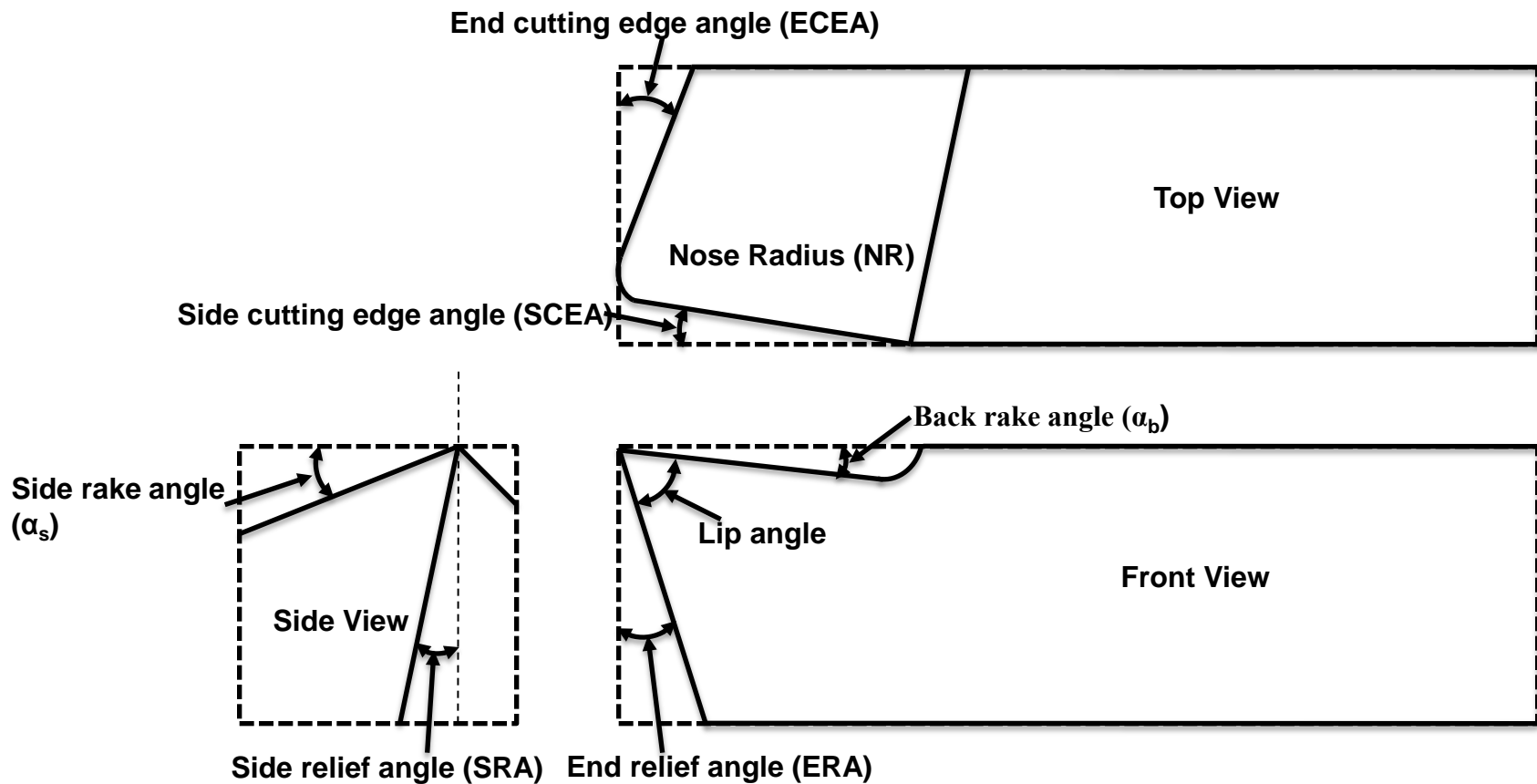

# Single Point Cutting Tool Geometry

## Geometry of negative rake single point cutting tool

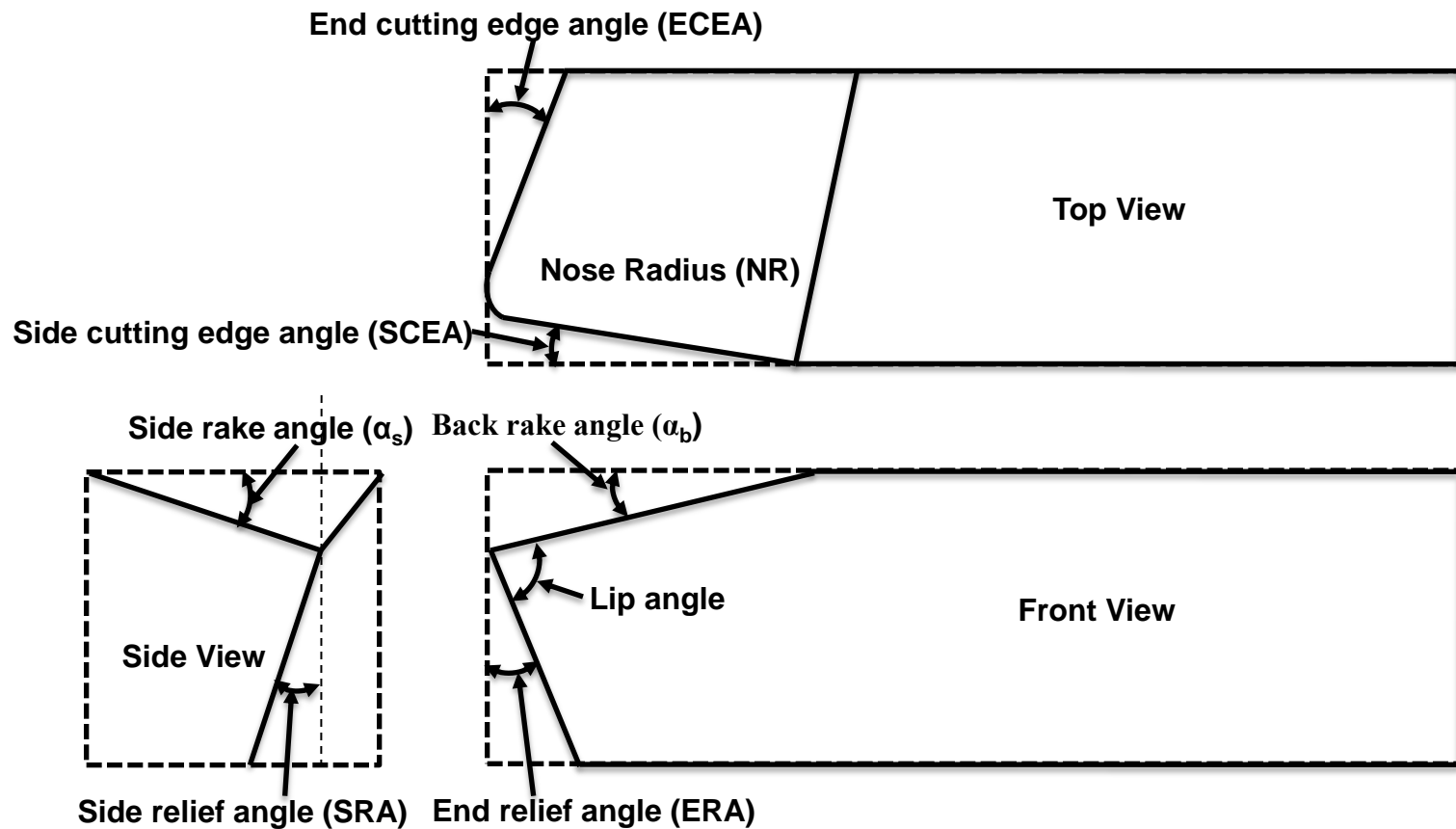

# Significance of Rake and Relief Angles

The Rake Angle [Click for video](#)



# Cutting tool angles and their significance

## Back rake angle:

- The back rake angle is the angle between the face of the tool and a line parallel to the base of the shank in a plane parallel to the side cutting edge.
- The back rake angle affects the ability of the tool to shear the work material and form chip.

## Side Rake Angles:

- It is the angle by which the face of the tool is inclined side ways.

## The Rake Angle:

The rake angle is always at the topside of the tool.

The side rake angle and the back rake angle combine to form the effective rake angle. This is also called true rake angle or resultant rake angle of the tool.

The basic tool geometry is determined by the rake angle of the tool.

Rake angle has two major effects during the metal cutting process.

One major effect of rake angle is its influence on tool strength. A tool with negative rake will withstand far more loading than a tool with positive rake.

The other major effect of rake angle is its influence on cutting pressure. A tool with a positive rake angle reduces cutting forces by allowing the chips to flow more freely across the rake surface.

# Cutting tool angles and their significance



# Cutting tool angles and their significance

The rake angle has the following function:

- It allows the chip to flow in convenient direction.
- It reduces the cutting force required to shear the metal and consequently helps to increase the tool life and reduce the power consumption. It provides keenness to the cutting edge.
- It improves the surface finish.

## Positive Rake:

- Positive rake or increased rake angle reduces compression, the forces, and the friction, yielding a thinner, less deformed and cooler chip.
- But increased rake angle reduces the strength of the tool section, and heat conduction capacity.
- Some areas of cutting where positive rake may prove more effective are, when cutting tough, alloyed materials that tend to work-harden, such as certain stainless steels, when cutting soft or gummy metals, or when low rigidity of workpiece, tooling, machine tool, or fixture allows chatter to occur.
- The shearing action and free cutting of positive rake tools will often eliminate problems in these areas.

# Cutting tool angles and their significance

## Negative Rake:

- To provide greater strength at the cutting edge and better heat conductivity, zero or negative rake angles are employed on carbide, ceramic, polycrystalline diamond, and polycrystalline cubic boron nitride cutting tools.
- These materials tend to be brittle, but their ability to hold their superior hardness at high temperature results in their selection for high speed and continuous machining operation.
- Negative rakes increases tool forces but this is necessary to provide added support to the cutting edge. This is particularly important in making intermittent cuts and in absorbing the impact during the initial engagement of the tool and work.
- Negative rakes are recommended on tool which does not possess good toughness (low transverse rupture strength).
- Thus negative rake (or small rake) causes high compression, tool force, and friction, resulting in highly deformed, hot chip.

## The rake angle for a tool depends on the following factors:

- **Type of material being cut:** A harder material like cast iron may be machined by smaller rake angle than that required by soft material like mild steel or aluminum.
- **Type of tool material:** Tool material like cemented carbide permits turning at very high speed. At high speeds rake angle has little influence on cutting pressure. Under such condition the rake angle can minimum or even negative rake angle is provided to increase the tool strength.
- **Depth of cut:** In rough turning, high depth of cut is given to remove maximum amount of material. This means that the tool has to withstand severe cutting pressure. So the rake angle should be decreased to increase the lip angle that provides the strength to the cutting edge.
- **Rigidity of the tool holder and machine:** An improperly supported tool on old or worn out machine cannot take up high cutting pressure. So while machining under the above condition, the tool used should have larger rake angle.



# Relief Angles

- Relief angles are provided to minimize physical interference or rubbing contact with machined surface and the work piece.
- Relief angles are for the purpose of helping to eliminate tool breakage and to increase tool life.
- If the relief angle is too large, the cutting tool may chip or break. If the angle is too small, the tool will rub against the workpiece and generate excessive heat and this will in turn, cause premature dulling of the cutting tool.
- Small relief angles are essential when machining hard and strong materials and they should be increased for the weaker and softer materials.
- A smaller angle should be used for interrupted cuts or heavy feeds, and a larger angle for semi-finish and finish cuts.

**Side relief angle:** The Side relief angle prevents the side flank of the tool from rubbing against the work when longitudinal feed is given. Larger feed will require greater side relief angle.

**End relief angle:** The End relief angle prevents the side flank of the tool from rubbing against the work. A minimum relief angle is given to provide maximum support to the tool cutting edge by increasing the lip angle. The front clearance angle should be increased for large diameter works.

# Cutting tool angles and their significance

## Side cutting edge angle:

The following are the advantages of increasing this angle:

- It increases tool life as, for the same depth of cut; the cutting force is distributed on a wider surface.
- It diminishes the chip thickness for the same amount of feed and permits greater cutting speed.
- It dissipates heat quickly for having wider cutting edge.
- The side cutting edge angle of the tool has practically no effect on the value of the cutting force or power consumed for a given depth of cut and feed.
- Large side cutting edge angles are likely to cause the tool to chatter.

## End cutting edge angle:

The function of end cutting edge angle is to prevent the trailing front cutting edge of the tool from rubbing against the work. A large end cutting edge angle unnecessarily weakens the tool.

It varies from 8 to 15 degrees.

# Cutting tool angles and their significance

## Nose radius:

The nose of a tool is slightly rounded in all turning tools.

The function of nose radius is as follows:

- Greater nose radius clears up the feed marks caused by the previous shearing action and provides better surface finish.
- All finish turning tool have greater nose radius than rough turning tools.
- It increases the strength of the cutting edge, tends to minimize the wear taking place in a sharp pointed tool with consequent increase in tool life.
- Accumulation heat is less than that in a pointed tool which permits higher cutting speeds.

# Tool signature

It is the system of designating the principal angles of a single point cutting tool.

The signature is the sequence of numbers listing the various angles, in degrees, and the size of the nose radius.

There are several systems available like American standard system (ASA), Orthogonal rake system (ORS), Normal rake system (NRS), and Maximum rake system (MRS).

The system most commonly used is American Standard Association (ASA), which is:

Bake rake angle, Side rake angle, End relief angle, Side relief angle, End cutting Edge angle, Side cutting Edge angle and Nose radius.

## Tool signature

For example a tool may be designated in the following sequence:

8-14-6-6-6-15-1

1. Back rake angle is 8
2. Side rake angle is 14
3. End relief angle is 6
4. Side relief angle is 6
5. End cutting Edge angle is 6
6. Side cutting Edge angle is 15
7. Nose radius is 1 mm

**Tool C**

---

**Tool**

# Designations for a Right-Handed Cutting Tool

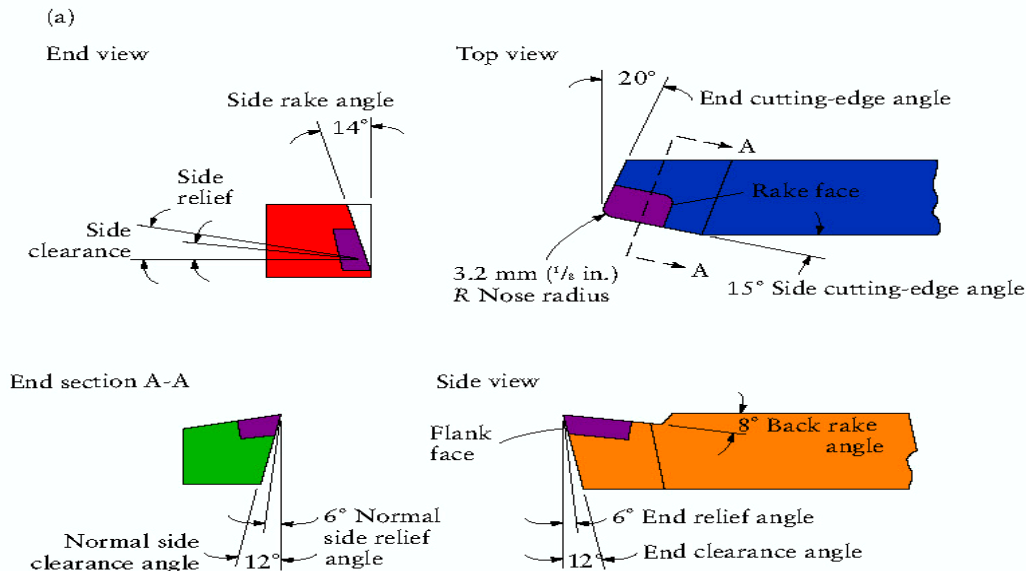
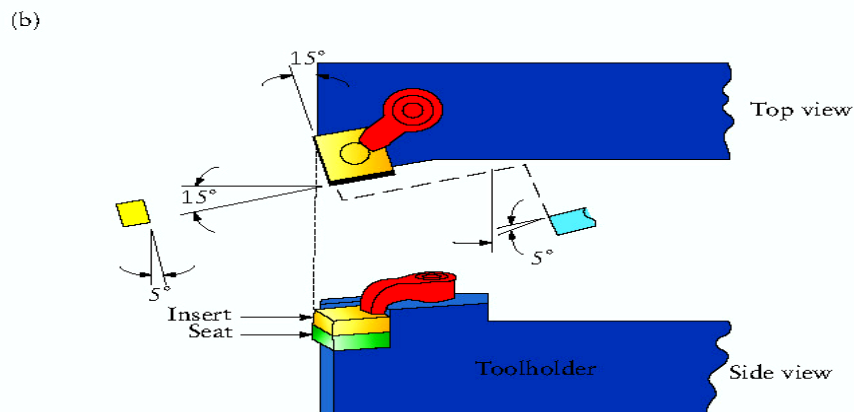

FIGURE: (a) Designations and symbols for a right-hand cutting tool; solid high-speed-steel tools have a similar designation. (b) Square insert in a right-hand toolholder for a turning operation. A wide variety of toolholder is available for holding inserts at various angles. Thus, the angles shown in (a) can be achieved easily by selecting an appropriate insert and toolholder. *Source: Kennametal, Inc.*

Tool Signature	Dimensions	Abbreviation
8	.Back rake angle	BR
14	.Side rake angle	SR
6	.End relief angle	ER
12	.End clearance angle	...
6	.Side relief angle	SRF
12	.Side clearance angle	...
20	.End cutting-edge angle	ECEA
15	.Side cutting-edge angle	SCEA
1/8	.Nose radius	NR



# THEORY OF METAL CUTTING

- The process of metal removal, a process in which a wedge-shaped tool engages a workpiece to remove a layer of material in the form of a chip, goes back many years.

*Video showing the wedge-shape of different tools.*



- Even with all of the sophisticated equipment and techniques used in today's modern industry, the basic mechanics of forming a chip remain the same.
- As the cutting tool engages the workpiece, the material directly ahead of the tool is sheared and deformed under tremendous pressure. The deformed material then seeks to relieve its stressed condition by fracturing and flowing into the space above the tool in the form of a chip.

## Orthogonal and Oblique Cutting

The two basic methods of metal cutting using a single point tool are the orthogonal (2 D) and oblique (3D). Orthogonal cutting takes place when the cutting face of the tool is 90 degree to the line of action of the tool. If the cutting face is inclined at an angle less than 90 degree to the line of action of the tool, the cutting action is known as oblique.

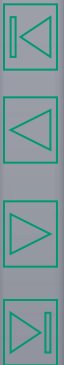



# Orthogonal and Oblique Cutting

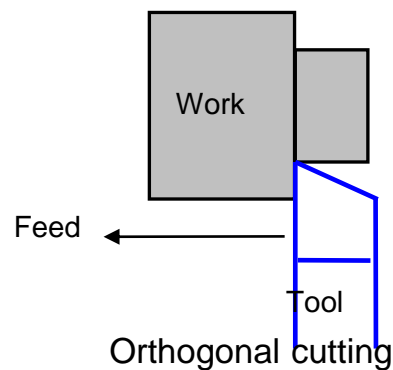

## Orthogonal Cutting:

- The cutting edge of the tool remains normal to the direction of tool feed or work feed.
- The direction of the chip flow velocity is normal to the cutting edge of the tool.
- Here only two components of forces are acting: Cutting Force and Thrust Force. So the metal cutting may be considered as a two dimensional cutting.

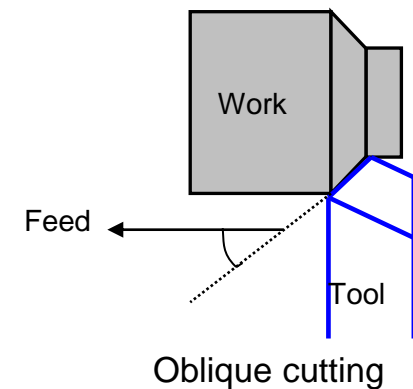

## Oblique Cutting:

- The cutting edge of the tool remains inclined at an acute angle to the direction of tool feed or work feed.
- The direction of the chip flow velocity is at an angle with the normal to the cutting edge of the tool. The angle is known as chip flow angle.
- Here three components of forces are acting: Cutting Force, Radial force and Thrust Force or feed force. So the metal cutting may be considered as a three dimensional cutting.
- The cutting edge being oblique, the shear force acts on a larger area and thus tool life is increased.

# Oblique Cutting

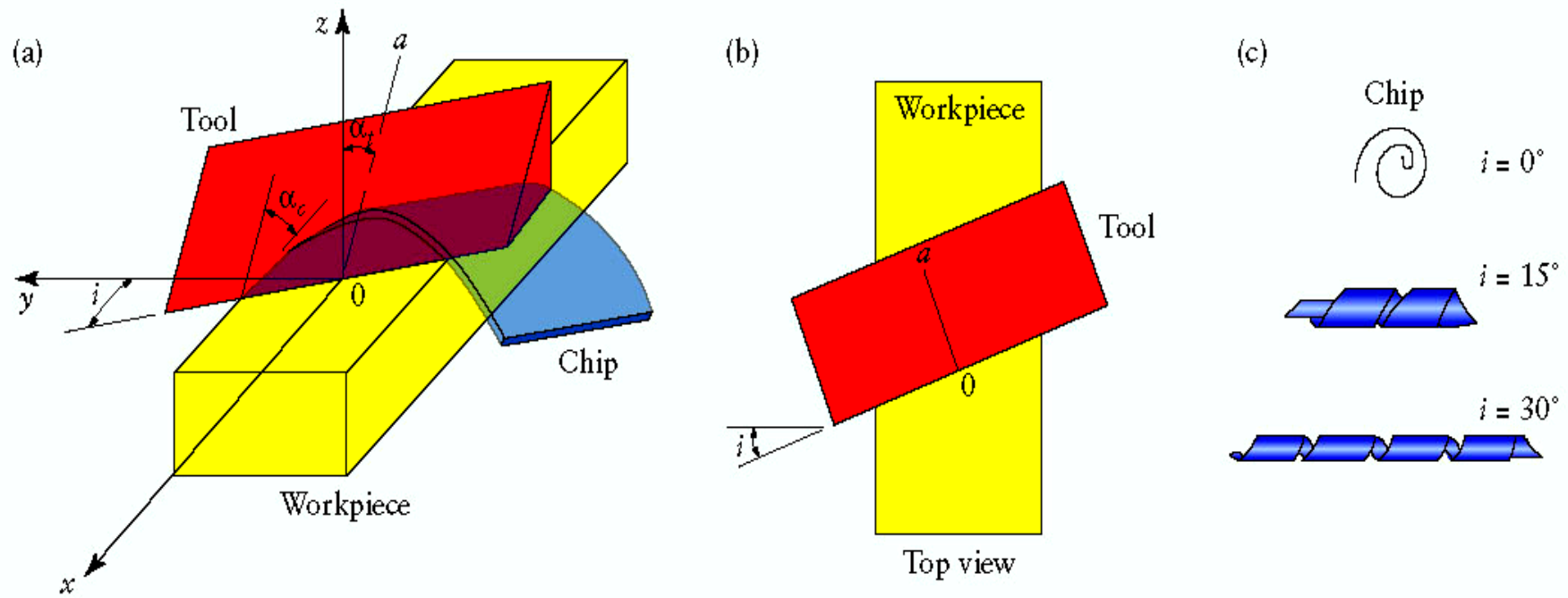

FIGURE (a) Schematic illustration of cutting with an oblique tool. (b) Top view, showing the inclination angle  $i$ . (c) Types of chips produced with different inclination angles

Source: “Manufacturing Processes for Engineering Materials”, 4<sup>th</sup> edition, Kalpakjian, Schmid, Prentice Hall 2003

# Mechanics of orthogonal metal cutting

During metal cutting, the metal is severely compressed in the area in front of the cutting tool.

This causes high temperature shear, and plastic flow if the metal is ductile.

When the stress in the workpiece just ahead of the cutting tool reaches a value exceeding the ultimate strength of the metal, particles will shear to form a chip element, which moves up along the face of the work.

The outward or shearing movement of each successive element is arrested by work hardening and the movement transferred to the next element.

The process is repetitive and a continuous chip is formed.

The plane along which the element shears, is called shear plane.

[Click for video](#)

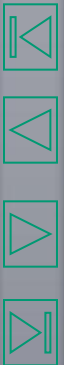

# Assumptions in orthogonal metal cutting

- No contact at the flank i.e. the tool is perfectly sharp.
- No side flow of chips i.e. width of the chips remains constant.
- Uniform cutting velocity.
- A continuous chip is produced with no built up edge.
- The chip is considered to be held in equilibrium by the action of the two equal and opposite resultant forces  $R$  and  $R'$  and assume that the resultant is collinear.

# Metal cutting Terminologies

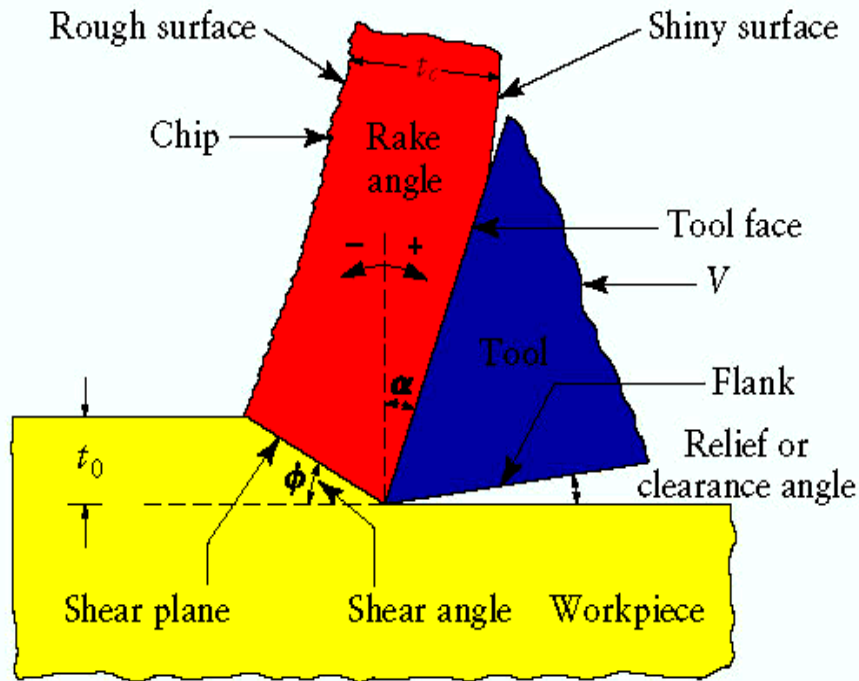

Schematic illustration of a two-dimensional cutting process (also called *orthogonal cutting*).

Source: “Manufacturing Processes for Engineering Materials”, 4<sup>th</sup> edition, Kalpakjian, Schmid, Prentice Hall 2003

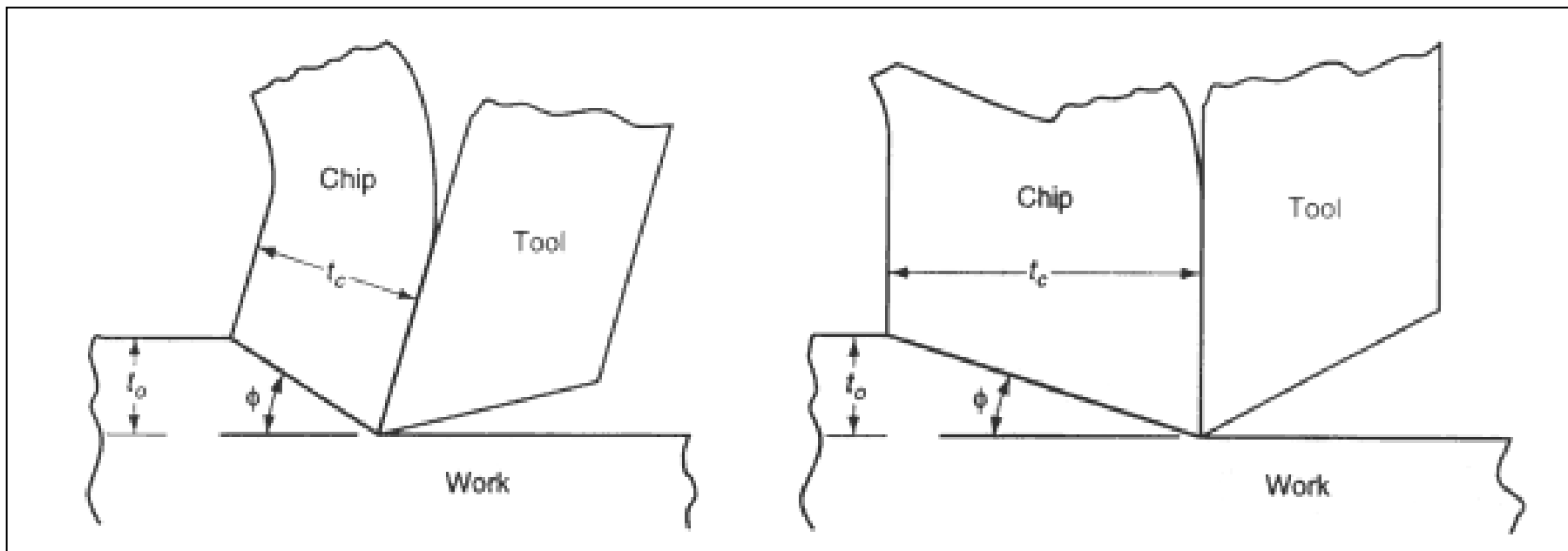

# Chip thickness ratios

The outward flow of the metal causes the chip to be thicker after the separation from the parent metal. That is the chip produced is thicker than the depth of cut.

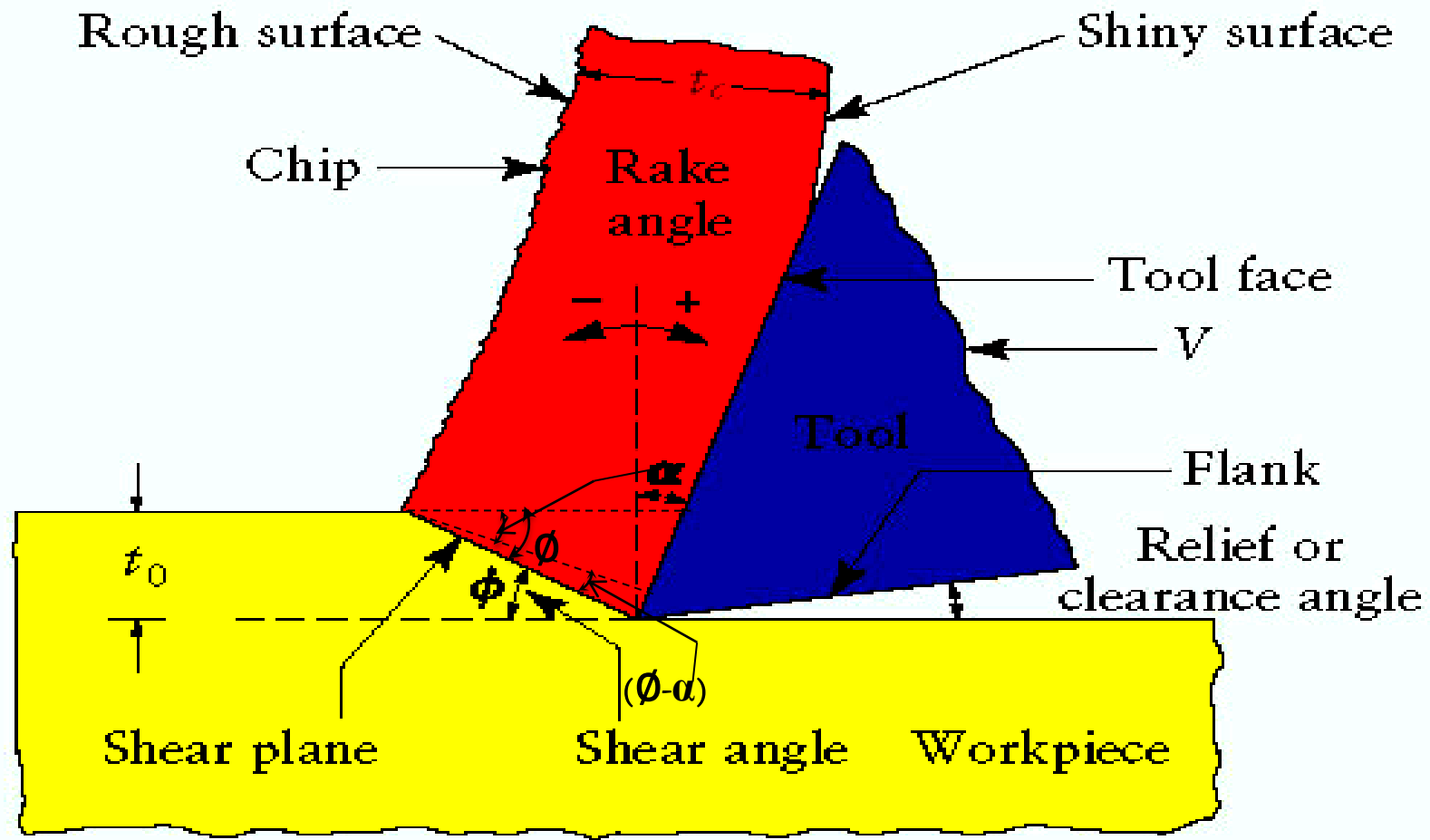



# Chip thickness ratio

## Chip thickness ratio

$$r = \frac{t_o}{t_c} = \frac{l_s \sin \phi}{l_s \cos(\phi - \alpha)}$$

$$r = \frac{\sin \phi}{\cos(\phi - \alpha)}$$

$$r = \frac{1}{r_c} = \frac{t_o}{t_c} = \frac{\sin \phi}{\cos(\phi - \alpha)}$$

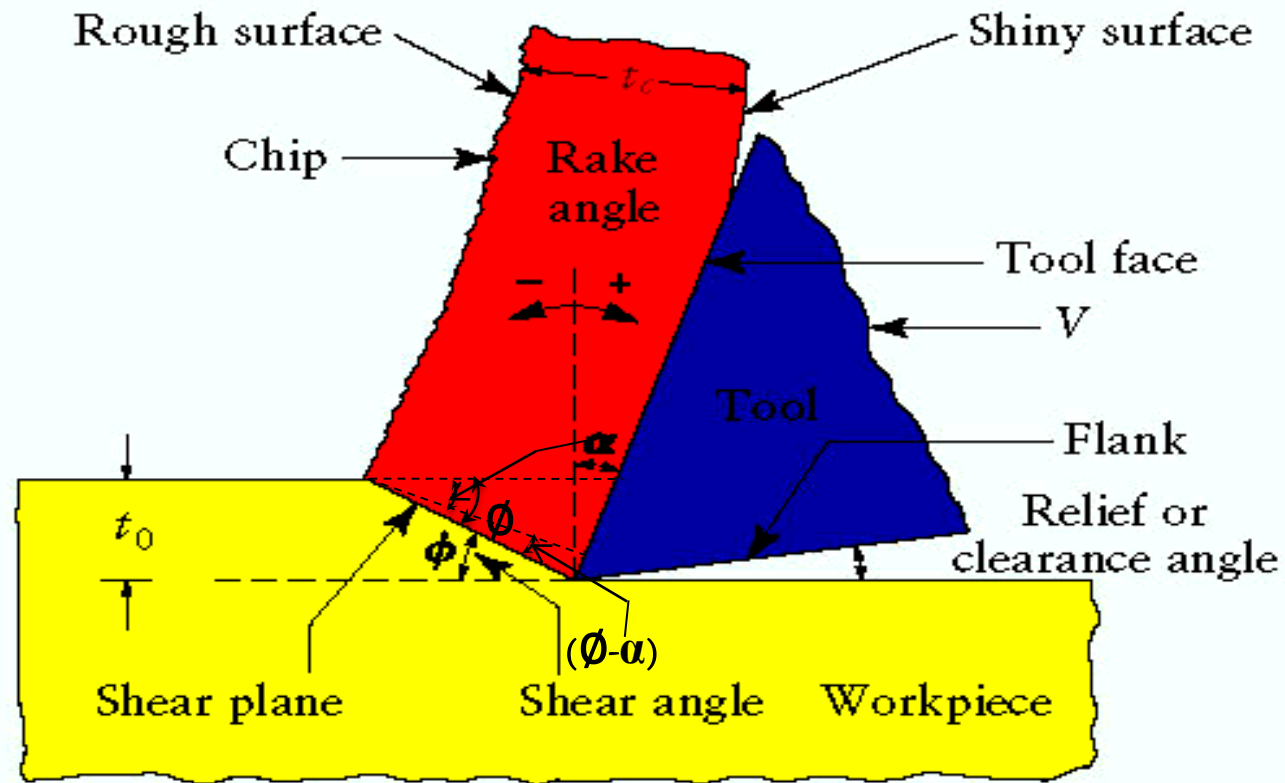

Rearranging:

$$\tan \phi = \frac{r \cos \alpha}{1 - r \sin \alpha}$$

# Velocity Relationship

Rake angle,  $\alpha$

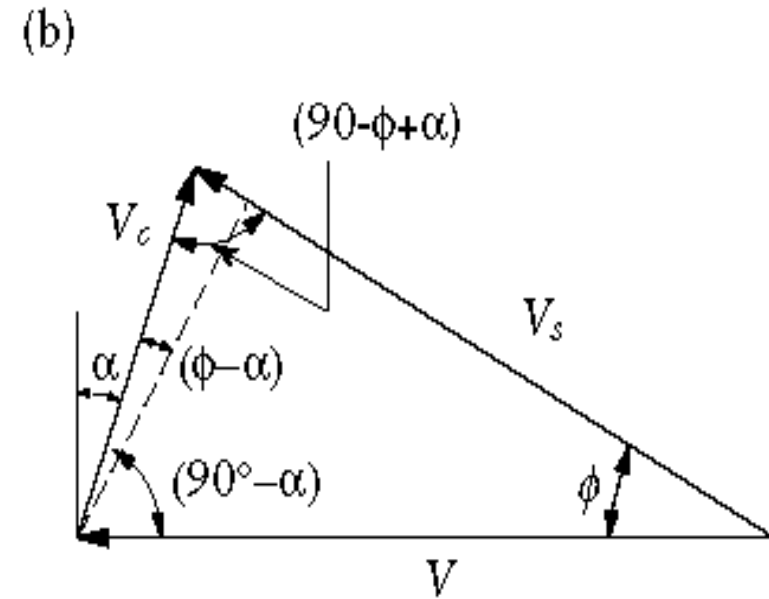
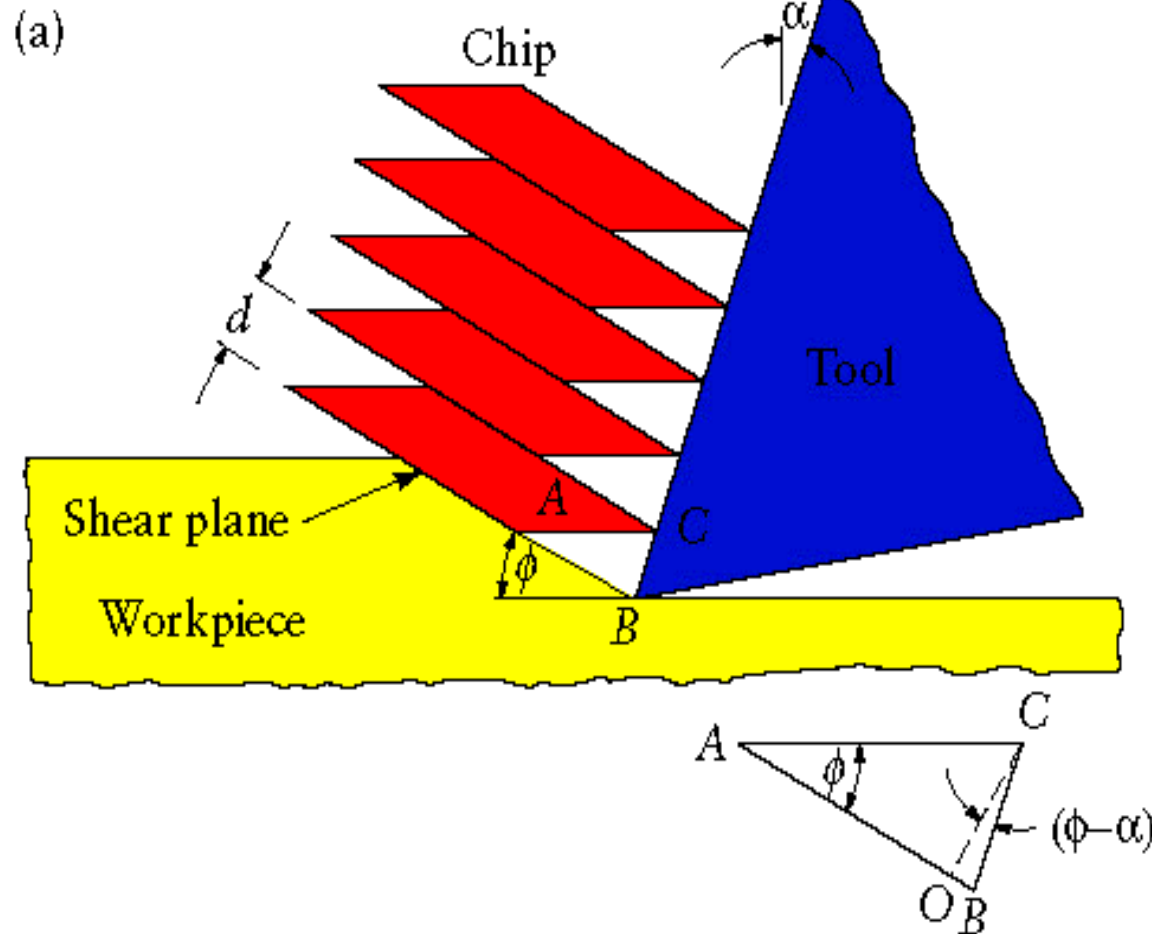
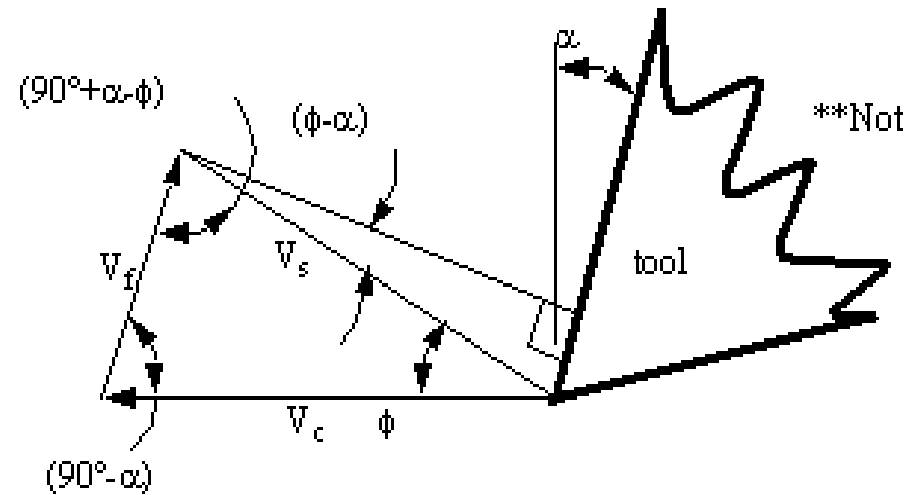
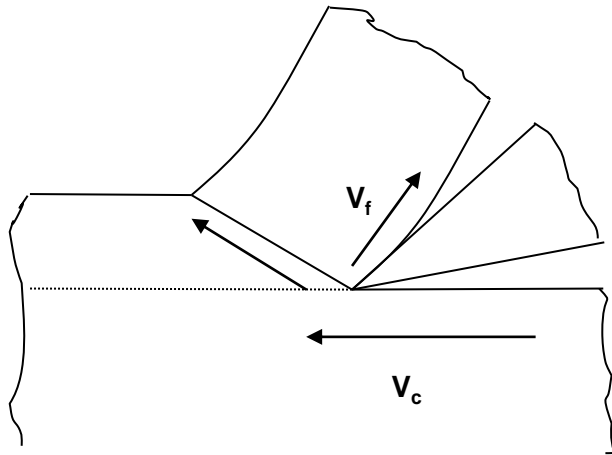

FIGURE (a) Schematic illustration of the basic mechanism of chip formation in cutting. (b) Velocity diagram in the cutting zone

Source “Manufacturing Processes for Engineering Materials”, 4<sup>th</sup> edition, Kalpakjian, Schmid, Prentice Hall 2003

# Velocity Relationship



Analytically,

$$\frac{v_c}{\sin(90 - (\phi - \alpha))} = \frac{v_f}{\sin \phi} = \frac{v_s}{\sin(90 - \alpha)}$$

$$\frac{v_c}{\cos(\phi - \alpha)} = \frac{v_f}{\sin \phi} = \frac{v_s}{\cos \alpha}$$

where,

$V_c$  = cutting velocity (ft./min.) - as set or measured on

$V_s$  = shearing velocity

$V_f$  = frictional velocity

$$v_f = \frac{v_c \sin \phi}{\cos(\phi - \alpha)}$$

$$\left[ r = \frac{\sin \phi}{\cos(\phi - \alpha)} \right]$$

$$v_f = v_c \times r$$

$$v_s = \frac{v_c \cos \alpha}{\cos(\phi - \alpha)}$$

Volume of material per unit time = Volume of material flowing up the chip

$$\Rightarrow v_c \times t_0 \times w = v_f \times t_c \times w$$

$$\Rightarrow v_f = v_c \times r \quad \text{As, } r = \frac{t_0}{t_c}$$

# Cutting forces

The force system in general case of conventional turning process

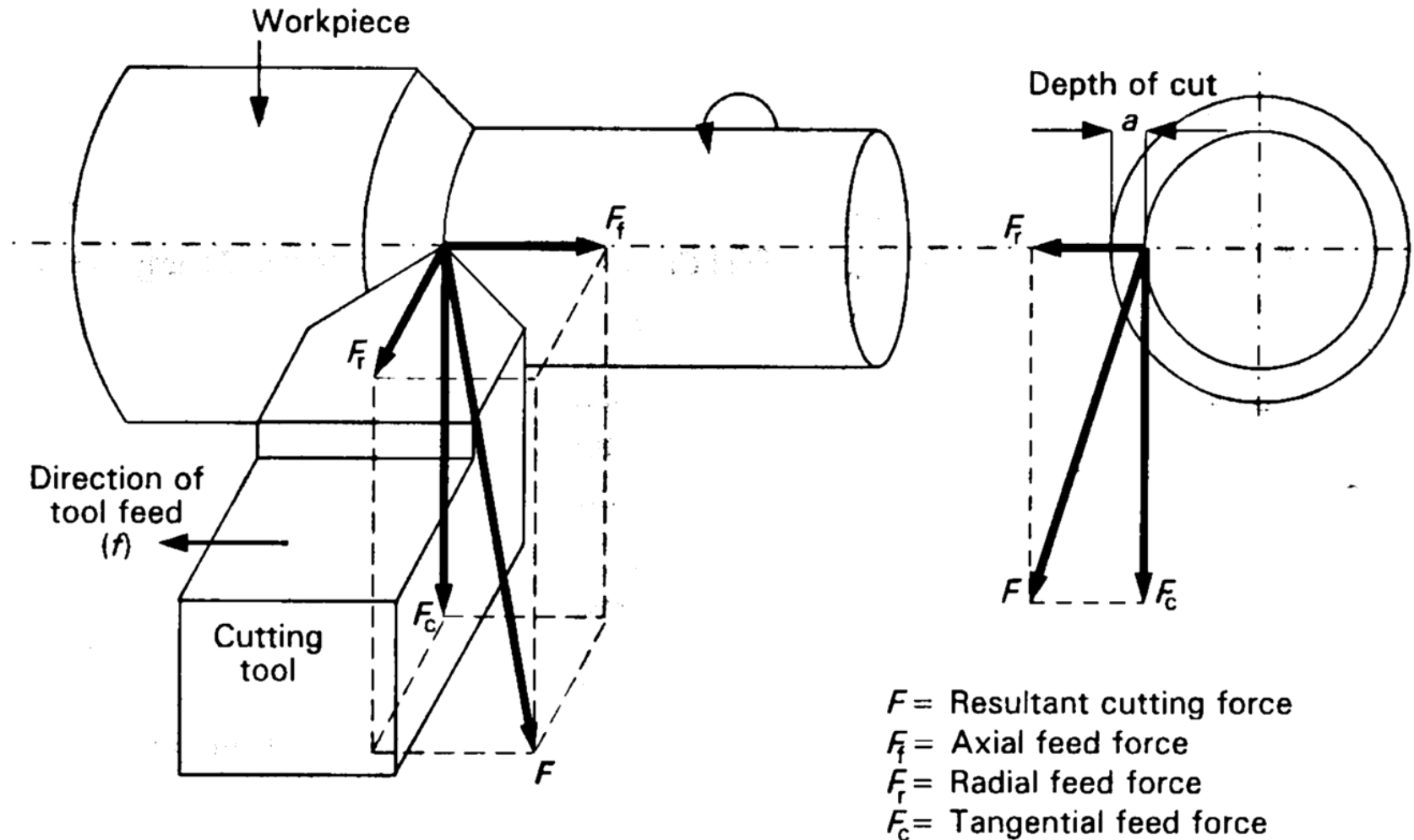

Primary forces involved in single-edge cutting. (Courtesy of Sandvik Coromant, Halesowen.)

# Cutting forces

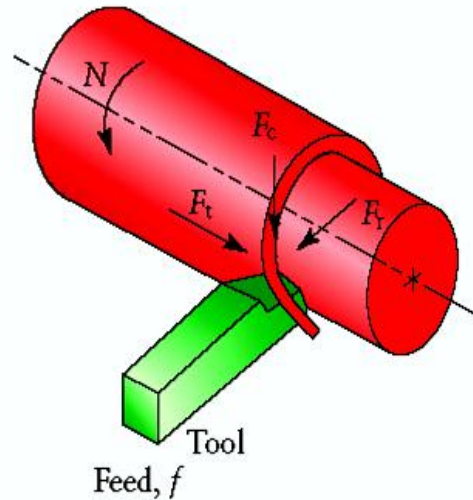

The largest magnitude is the vertical force  $F_c$  which in turning is larger than feed force  $F_f$ , and  $F_f$  is larger than radial force  $F_r$ .

For orthogonal cutting system  $F_r$  is made zero by placing the face of cutting tool at 90 degree to the line of action of the tool.

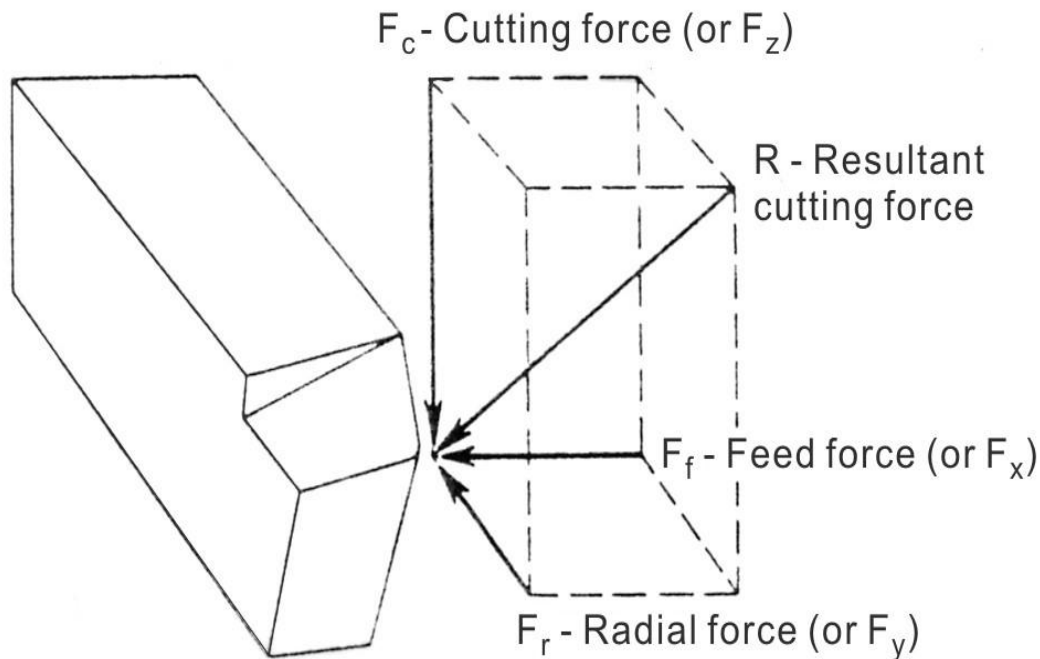

$$\begin{aligned}\bar{R} &= \bar{F}_x + \bar{F}_y + \bar{F}_z \\ &= \bar{F}_c + \bar{F}_f + \bar{F}_r\end{aligned}$$

↑ Tangential Force (Cutting Force)  
↑ Feed Force  
↑ Radial Force

In orthogonal cutting

$$\bar{R} = \bar{F}_c + \bar{F}_t$$

↑ Thrust Force



# Cutting forces in oblique cutting

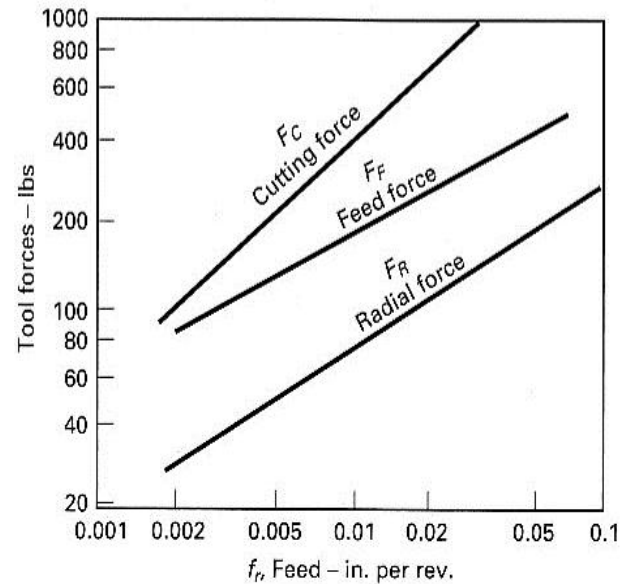
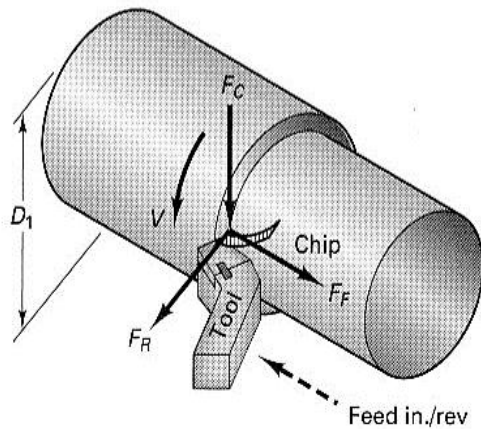
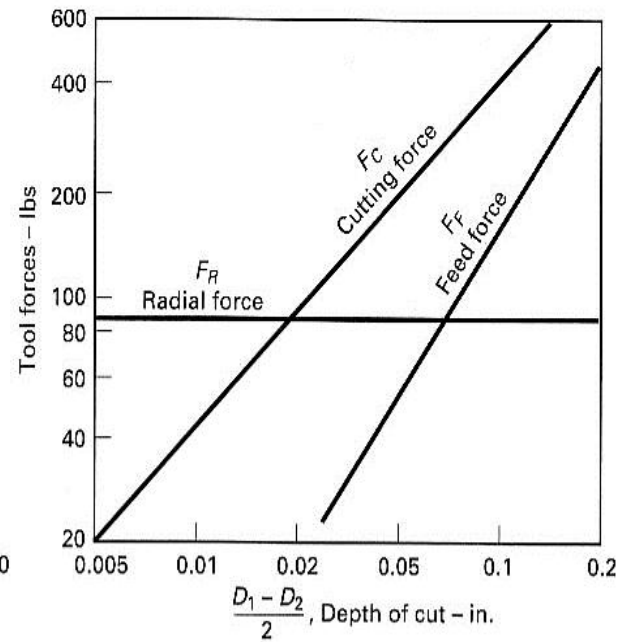
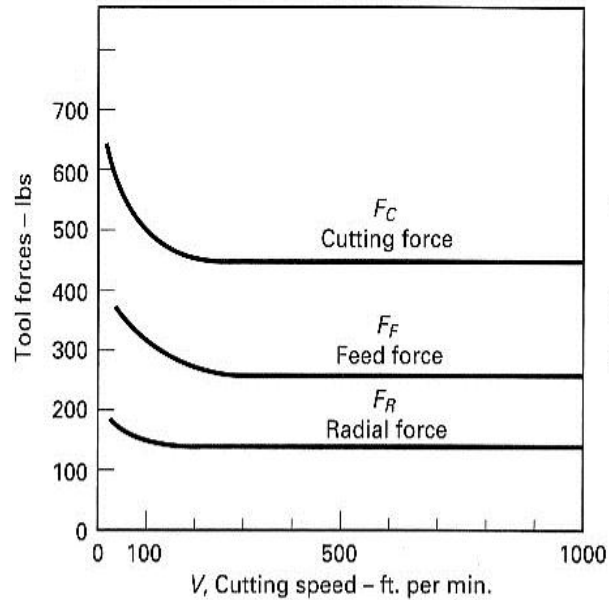

From DeGarmo, E. P., J. T. Black, and R. A. Kohser, Materials and processes in Manufacturing, PHI.

# The forces in orthogonal cutting (turning)

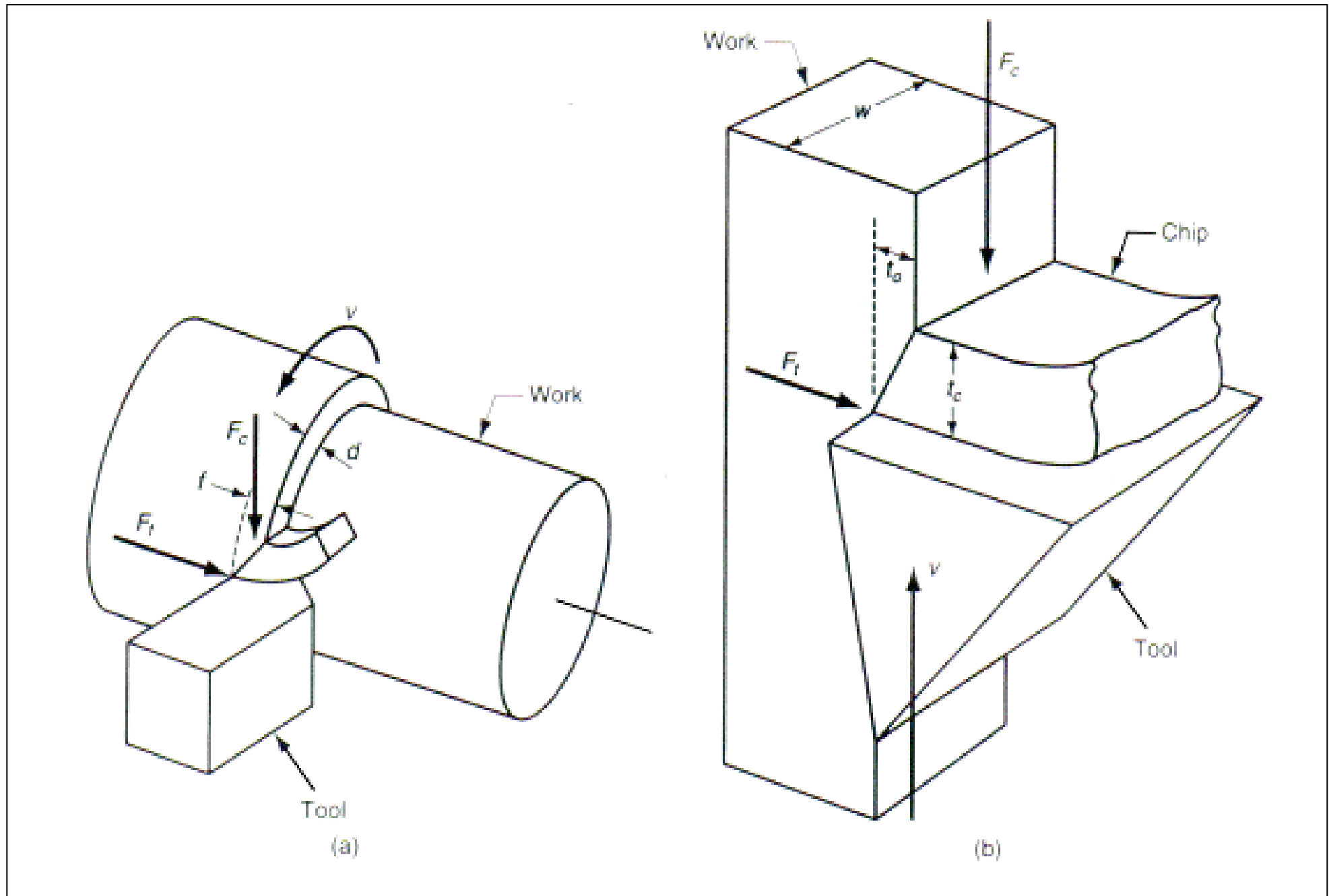

# Forces acting on Chip in two-dimensional cutting

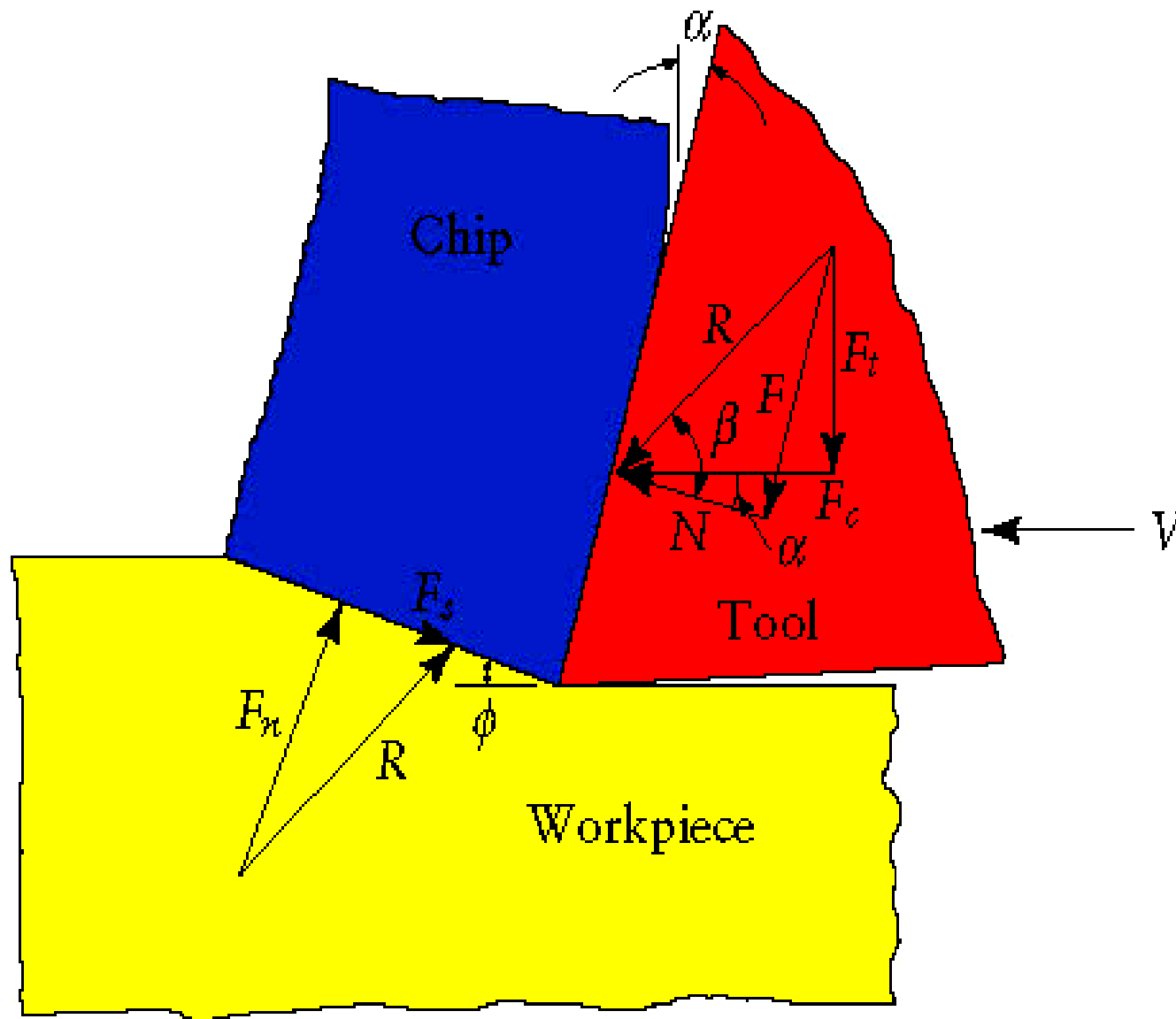

Source “ Manufacturing Processes for Engineering Materials”, 4<sup>th</sup> edition, Kalpakjian, Schmid, Prentice Hall 2003

# The forces acting on the chip in orthogonal cutting

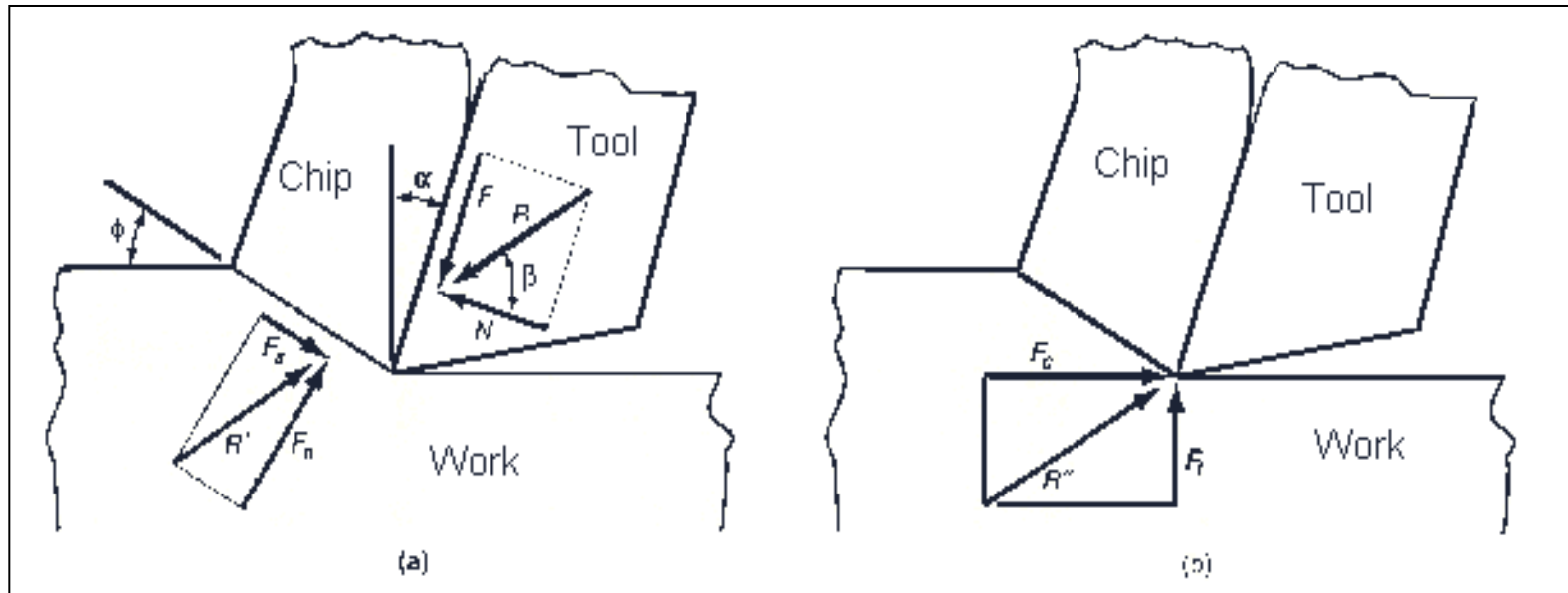

$$\vec{R}' = \vec{N} + \vec{F}$$

$$\vec{R} = \vec{F}_S + \vec{F}_N$$

$F_s$  = Shear Force, which acts along the shear plane, is the resistance to shear of the metal in forming the chip.

$F_n$  = Force acting normal to the shear plane, is the backing up force on the chip provided by the workpiece.

$F$  = Frictional resistance of the tool acting against the motion of the chip as it moves upward along the tool.

$N$  = Normal to the chip force, is provided by the tool.

It is assumed that the resultant forces  $R$  &  $R'$  are equal and opposite in magnitude and direction. Also they are Collinear. Therefore for the purpose of analysis the chip is regarded as an independent body held in mechanical equilibrium by the action of two equal and opposite forces  $R$ , which the workpiece exerts upon the chip and  $R'$  which the tool exerts upon the chip.

# Merchant's Circle Diagram

The following is a circle diagram. Known as Merchant's circle diagram, which is convenient to determine the relation between the various forces and angles. In the diagram two force triangles have been combined and  $R$  and  $R'$  together have been replaced by  $R$ . The force  $R$  can be resolved into two components  $F_c$  and  $F_t$ .  $F_c$  and  $F_t$  can be determined by force dynamometers.

$$\vec{R} = \vec{F}_c + \vec{F}_t$$

The rake angle ( $\alpha$ ) can be measured from the tool, and forces  $F$  and  $N$  can then be determined. The shear angle ( $\phi$ ) can be obtained from its relation with chip reduction coefficient. Now  $F_s$  &  $F_n$  can also be determined.

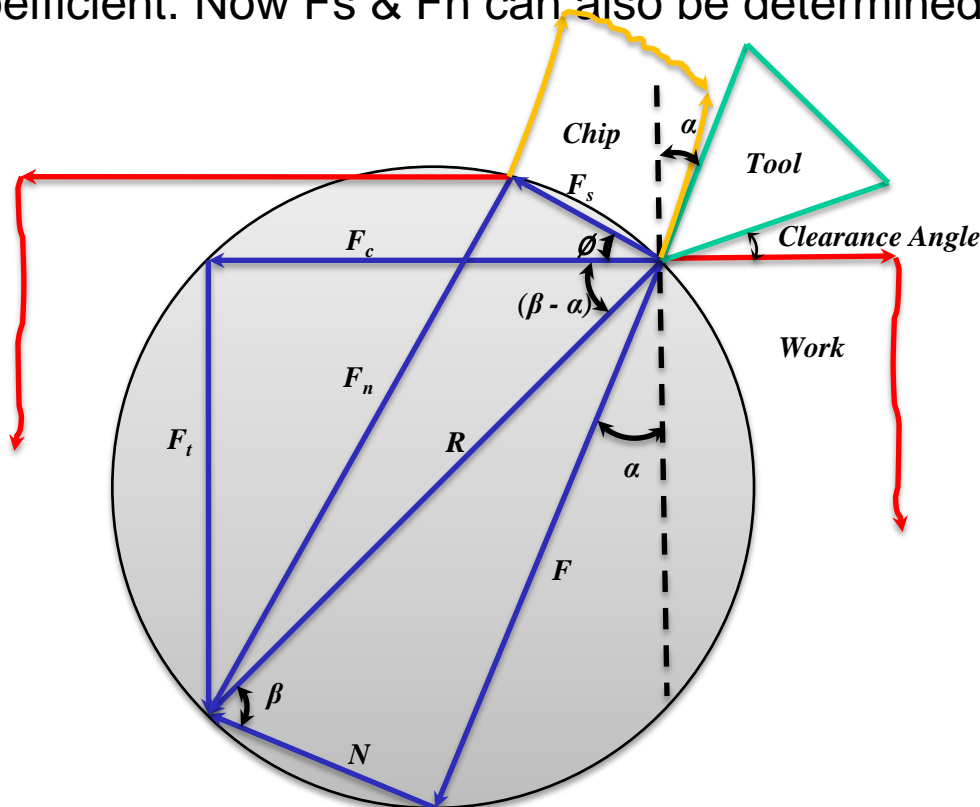

M. Eugene Merchant

# The procedure to construct a merchants circle diagram

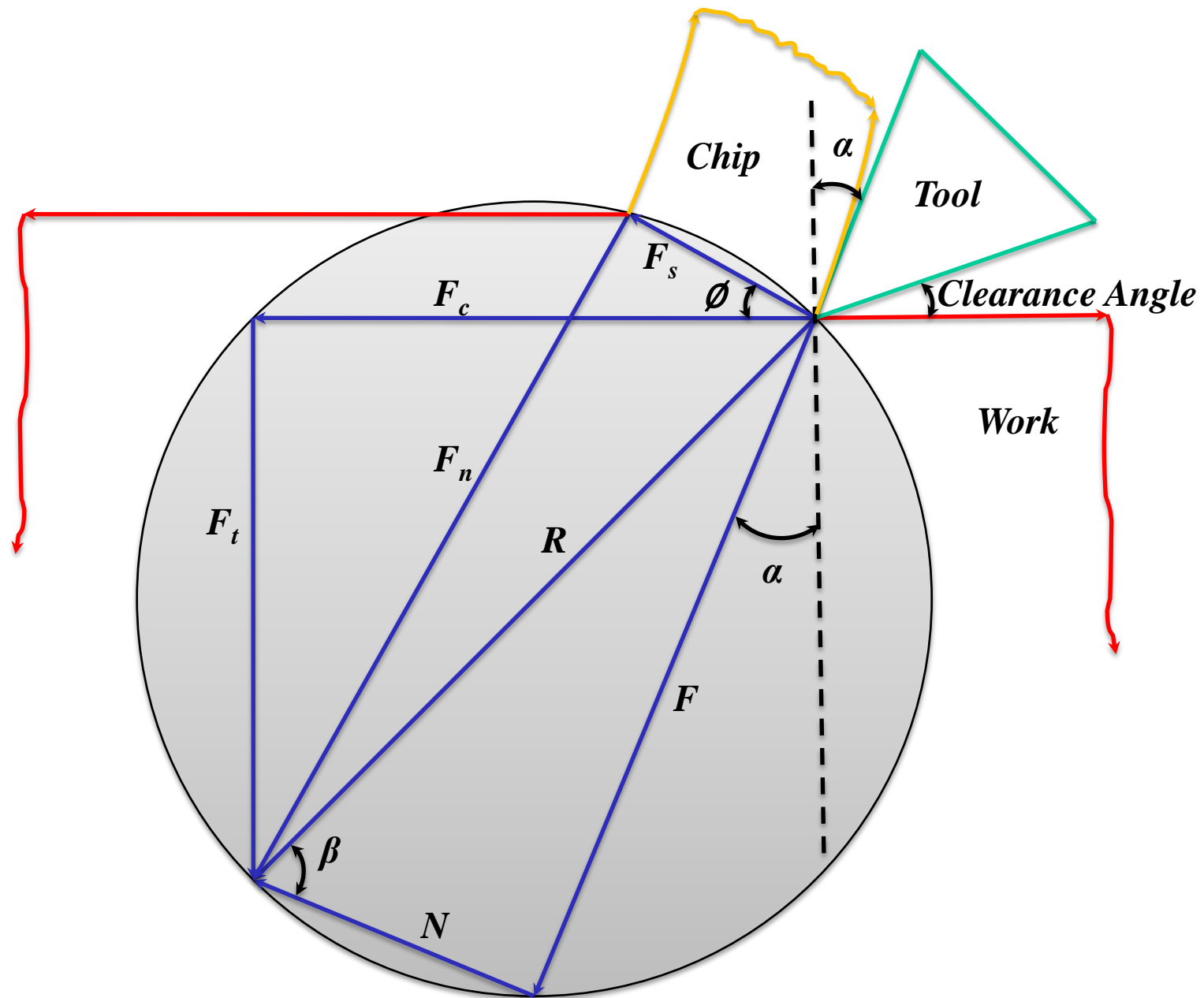



# The procedure to construct a merchants circle diagram

- Set up x-y axis labeled with forces, and the origin in the centre of the page. The cutting force ( $F_c$ ) is drawn horizontally, and the tangential force ( $F_t$ ) is drawn vertically. (Draw in the resultant ( $R$ ) of  $F_c$  and  $F_t$ .)
- Locate the centre of  $R$ , and draw a circle that encloses vector  $R$ . If done correctly, the heads and tails of all 3 vectors will lie on this circle.
- Draw in the cutting tool in the upper right hand quadrant, taking care to draw the correct rake angle ( $\alpha$ ) from the vertical axis.
- Extend the line that is the cutting face of the tool (at the same rake angle) through the circle. This now gives the friction vector ( $F$ ).
- A line can now be drawn from the head of the friction vector, to the head of the resultant vector ( $R$ ). This gives the normal vector ( $N$ ). Also add a friction angle ( $\beta$ ) between vectors  $R$  and  $N$ . Therefore, mathematically,  $R = F_c + F_t = F + N$ .
- Draw a feed thickness line parallel to the horizontal axis. Next draw a chip thickness line parallel to the tool cutting face.
- Draw a vector from the origin (tool point) towards the intersection of the two chip lines, stopping at the circle. The result will be a shear force vector ( $F_s$ ). Also measure the shear force angle between  $F_s$  and  $F_c$ .
- Finally add the shear force normal ( $F_n$ ) from the head of  $F_s$  to the head of  $R$ .
- Use a scale and protractor to measure off all distances (forces) and angles.

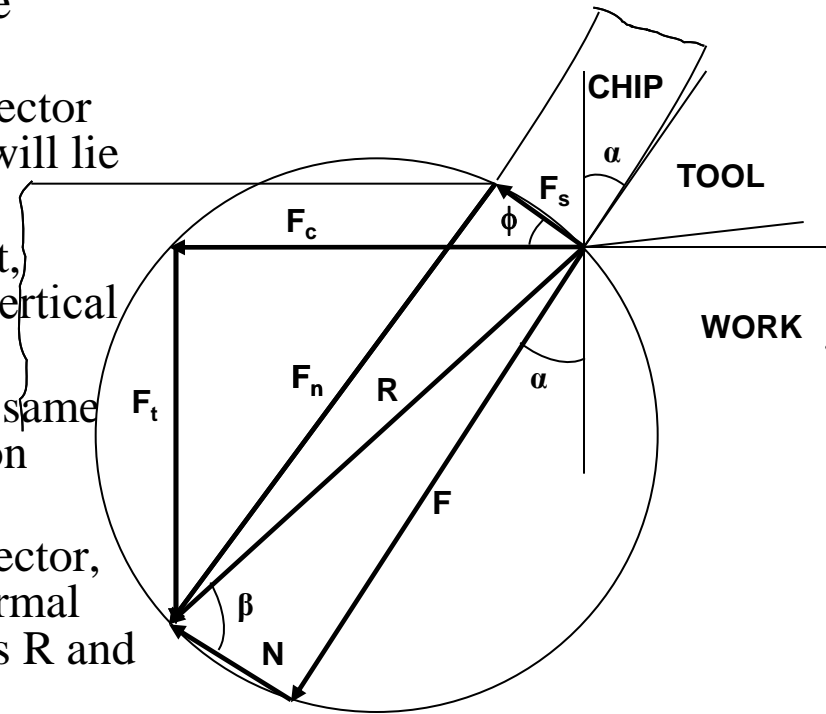

# Merchant's Circle Diagram

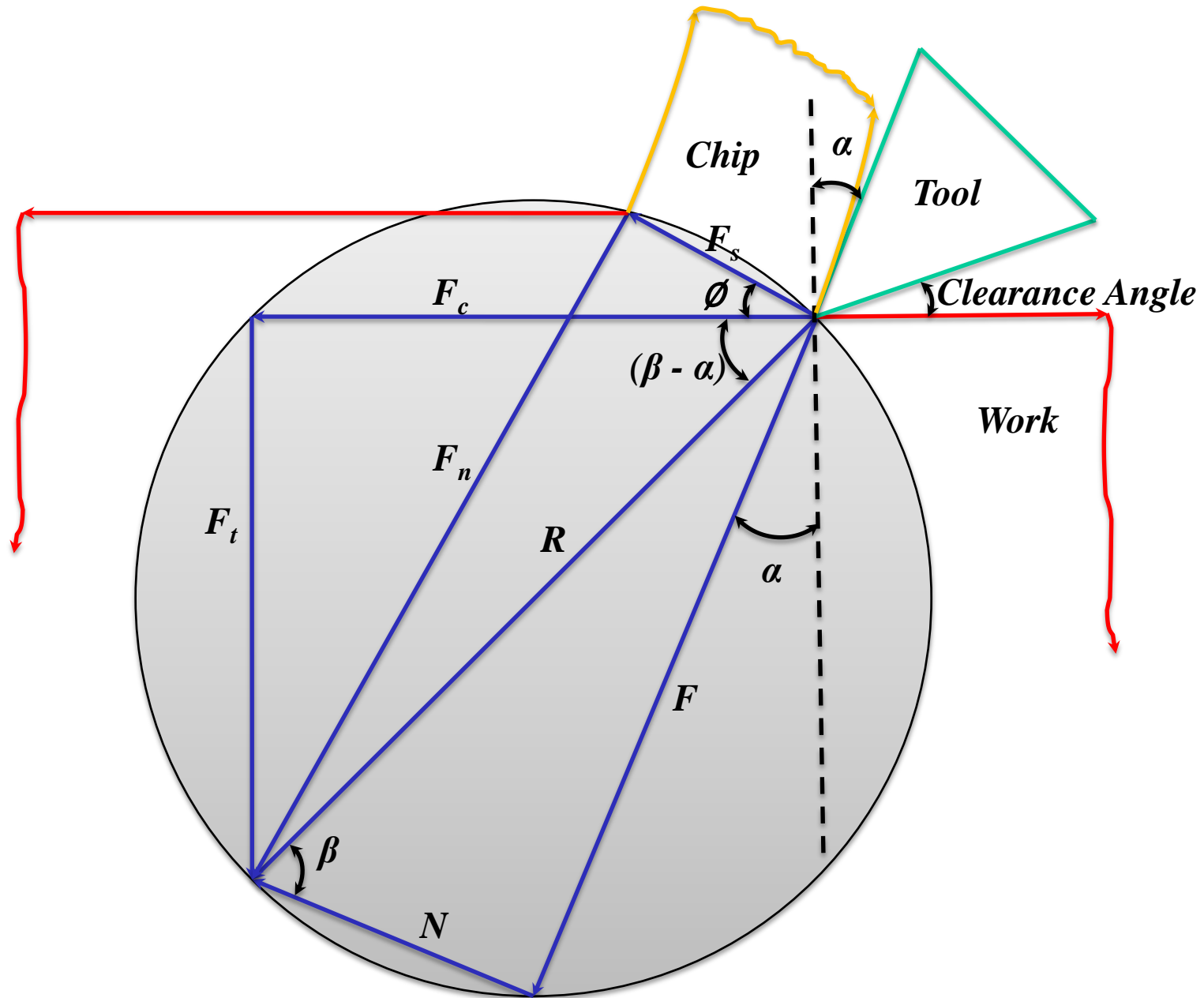

# Relationship of various forces acting on the chip with the horizontal and vertical cutting force from Merchant circle diagram

## Frictional Force System

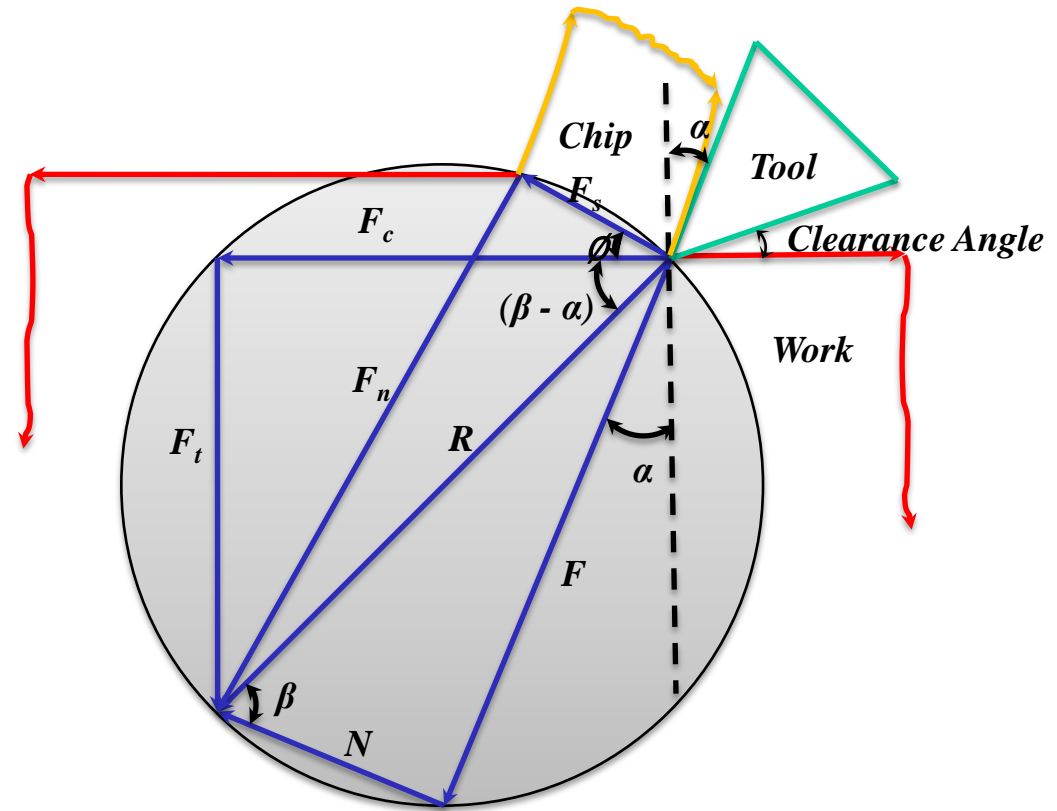
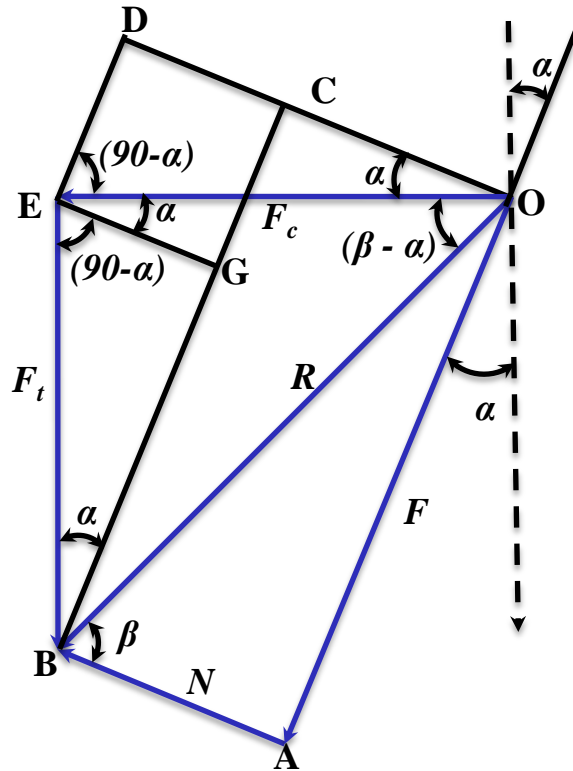

$$F = OA = CB = CG + GB = ED + GB$$

$$\Rightarrow F = F_c \sin \alpha + F_t \cos \alpha$$

$$N = AB = OD - CD = OD - GE$$

$$\Rightarrow N = F_c \cos \alpha - F_t \sin \alpha$$

The coefficient of friction

$$\mu = \tan \beta = \frac{F}{N}$$

Where  $\beta =$  Friction angle

# Relationship of various forces acting on the chip with the horizontal and vertical cutting force from Merchant circle diagram

## Shear Force System

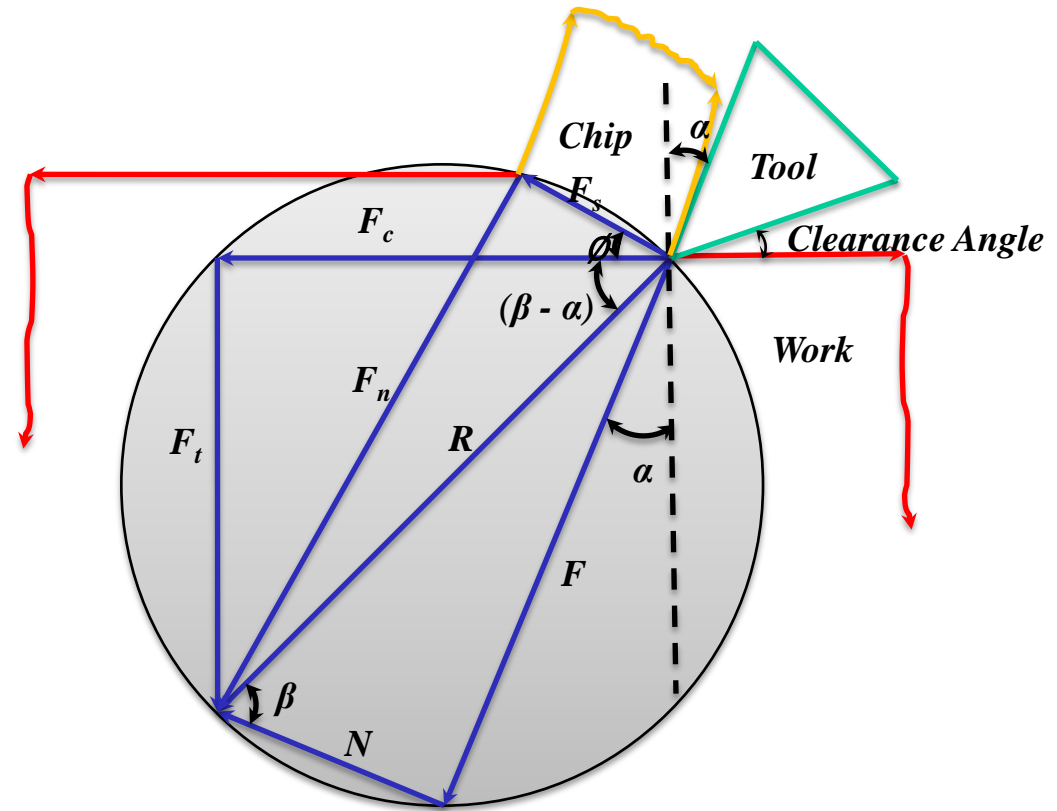
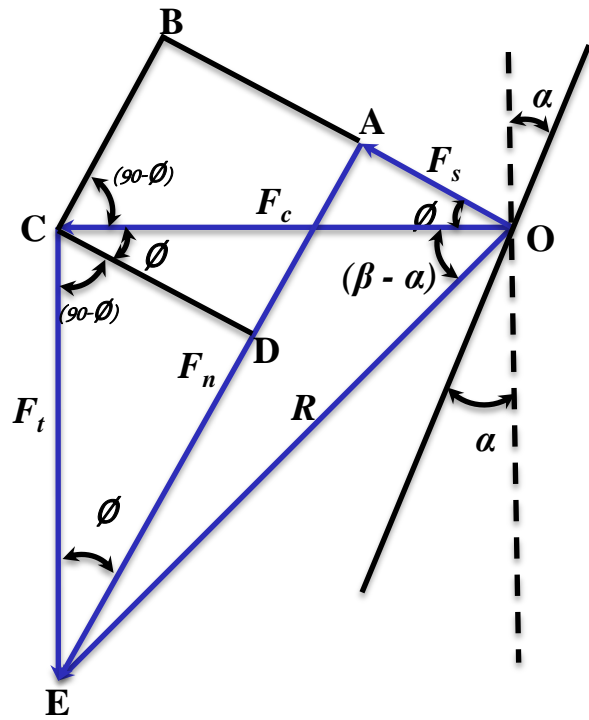

$$F_S = OA = OB - AB = OB - CD$$

$$\Rightarrow F_S = F_C \cos \phi - F_t \sin \phi$$

$$F_N = AE = AD + DE = BC + DE$$

$$\Rightarrow F_N = F_C \sin \phi + F_t \cos \phi$$

Also:

$$F_N = F_S \tan(\phi + \beta - \alpha)$$

# Relationship of various forces acting on the chip with the horizontal and vertical cutting force from Merchant circle diagram

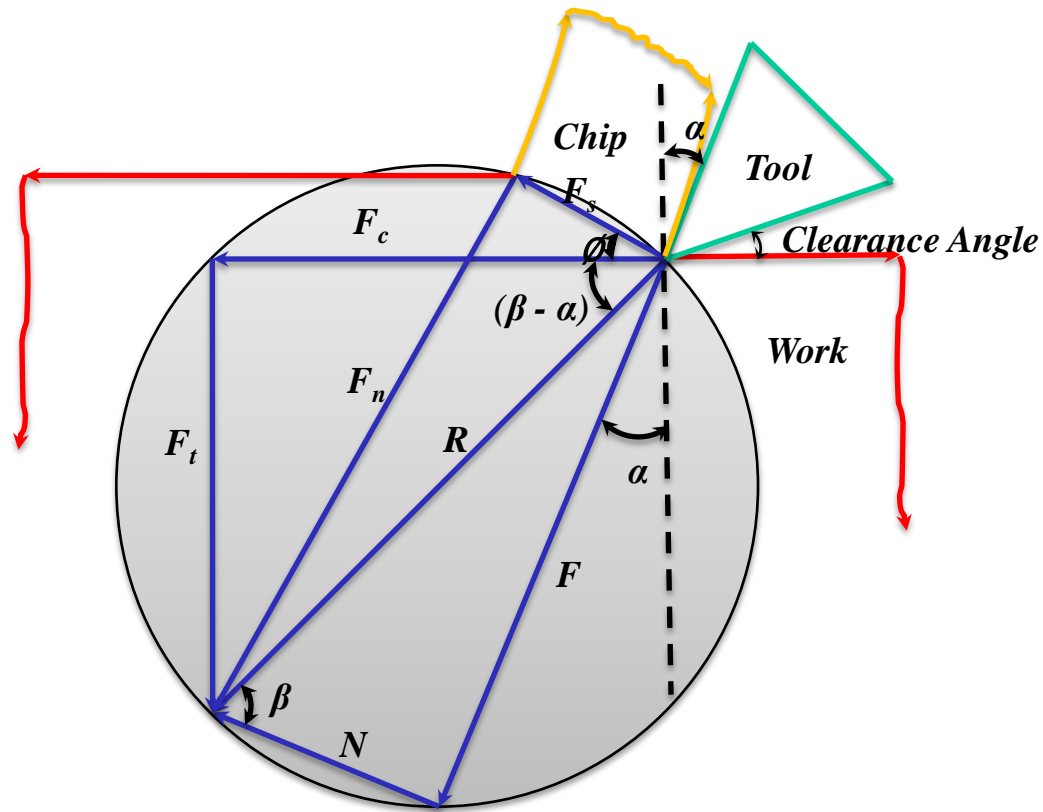

$$F = F_C \sin \alpha + F_t \cos \alpha$$

$$N = F_C \cos \alpha - F_t \sin \alpha$$

$$F_S = F_C \cos \phi - F_t \sin \phi$$

$$F_N = F_C \sin \phi + F_t \cos \phi$$

$$F_N = F_S \tan(\phi + \beta - \alpha)$$

# Power required in Metal cutting

The Power consumed/ work done per sec *in cutting*:  $P_C = F_C \times v_C$

The Power consumed/ work done per sec *in shear*:  $P_s = F_s \times v_s$

The Power consumed/ work done per sec *in friction*:  $P_F = F \times v_f$

**The total Power required:**

$P$  = Power supplied by the motor

$\Rightarrow P$  = Work consumed in cutting per sec + work spent in feeding per sec

$\Rightarrow P = F_c \times v_c + F_t \times \text{feed velocity}$

In comparison to the cutting velocity the feed velocity is very nominal. Similarly  $F_c$  is very small compared to  $F_s$ . So the work spent in feeding can be considered negligible.

Therefore, total power required in cutting  $P = P_c = P_s + P_f$



# Specific Energy

Specific Energy,  $u_t$ , is defined as the total energy per unit volume of material removed.

$$u_t = \frac{F_c v_c}{wt_0 v_c} = \frac{F_c}{wt_0}$$

Therefore is simply the cutting force to the projected area of cut.

If  $u_f$  and  $u_s$  be specific energy for friction and specific energy for shearing , then

$$u_t = u_f + u_s = \frac{F_f v_f}{wt_0 v_c} + \frac{F_s v_s}{wt_0 v_c} = \frac{F_f}{wt_0} + \frac{F_s v_s}{wt_0 v_c}$$

As the rake angle increases, the frictional specific energy remains more or less constant, where as the shear specific energy rapidly reduced.

# Approximate specific-energy requirements in cutting operations.

MATERIAL	SPECIFIC ENERGY*	
	W-s/mm <sup>3</sup>	hp-min/in <sup>3</sup>
Aluminum alloys	0.4-1.1	0.15-0.4
Cast irons	1.6-5.5	0.6-2.0
Copper alloys	1.4-3.3	0.5-1.2
High-temperature alloys	3.3-8.5	1.2-3.1
Magnesium alloys	0.4-0.6	0.15-0.2
Nickel alloys	4.9-6.8	1.8-2.5
Refractory alloys	3.8-9.6	1.1-3.5
Stainless steels	3.0-5.2	1.1-1.9
Steels	2.7-9.3	1.0-3.4
Titanium alloys	3.0-4.1	1.1-1.5

\* At drive motor, corrected for 80% efficiency; multiply the energy by 1.25 for dull tools.

Source “ Manufacturing Processes for Engineering Materials”, 4<sup>th</sup> edition, Kalpakjian, Schmid, Prentice Hall 2003

Ernest and Merchant gave the relation

$$\phi = \frac{\pi}{4} - \frac{1}{2}(\beta - \alpha)$$



M. Eugene Merchant

Assumptions of the theory:

- Tool edge is sharp.
- The work material undergoes deformation across a thin shear plane.
- There is uniform distribution of normal and shear stress on the shear plane.
- The work material is rigid and perfectly plastic.
- The shear angle  $\phi$  adjusts itself to give minimum work.
- The friction angle  $\beta$  remains constant and is independent of  $\phi$ .
- The chip width remains constant.

# Theory of Ernst and Merchant (1944)

$$F_s = R \cos(\phi + \beta - \alpha)$$

$$R = F_c \sec(\beta - \alpha)$$

$$\Rightarrow F_s = F_c \sec(\beta - \alpha) \cos(\phi + \beta - \alpha)$$

$$\tau_s = \frac{F_s}{A_s}$$

$$\text{where, } A_s = \frac{wt_0}{\sin \phi}$$

$$\Rightarrow \tau_s = \frac{F_c \sec(\beta - \alpha) \cos(\phi + \beta - \alpha)}{\frac{wt_0}{\sin \phi}}$$

$$\Rightarrow \tau_s = \frac{F_c \sec(\beta - \alpha) \cos(\phi + \beta - \alpha) \sin \phi}{wt_0}$$

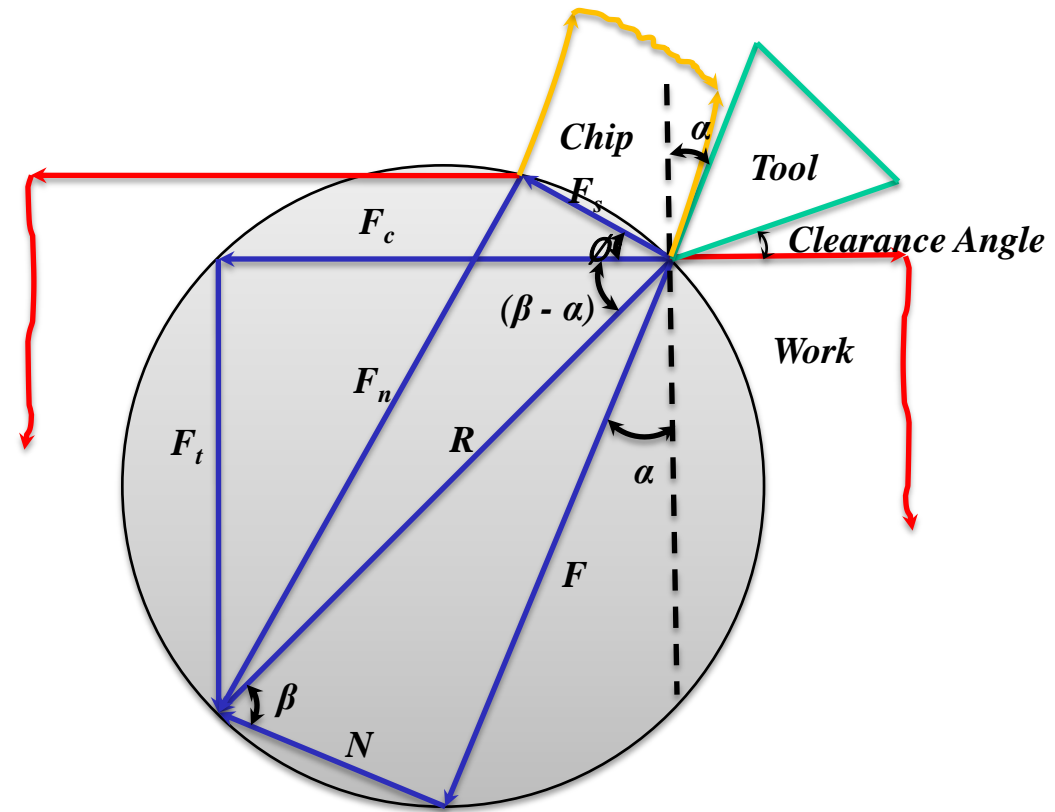

They have assumed that  $\phi$  adjusts itself to give minimum work. And for a given set of cutting condition,  $t_0$ ,  $w$  and  $\alpha$  are all constants. They also assumed that  $\beta$  is independent of  $\phi$ .

# Theory of Ernst and Merchant (1944)

We can either maximize  $\tau_s$  or minimize  $F_c$

Therefore in the above equation the term  $\cos(\phi + \beta - \alpha)\sin\phi$  contains only one variable  $\phi$ .

$$\text{let } y = \cos(\phi + \beta - \alpha)\sin\phi$$

$$\frac{dy}{d\phi} = -\sin(\phi + \beta - \alpha)\sin\phi + \cos(\phi + \beta - \alpha)\cos\phi$$

for maximum value of  $y$

$$\Rightarrow \frac{dy}{d\phi} = 0$$

$$\Rightarrow \sin(\phi + \beta - \alpha)\sin\phi = \cos(\phi + \beta - \alpha)\cos\phi$$

$$\Rightarrow \tan(\phi + \beta - \alpha) = \cot\phi$$

$$\Rightarrow \tan(\phi + \beta - \alpha) = \tan\left(\frac{\pi}{2} - \phi\right)$$

$$\Rightarrow \phi + \beta - \alpha = \frac{\pi}{2} - \phi$$

$$\Rightarrow \phi = \frac{\pi}{4} - \frac{1}{2}(\beta - \alpha)$$

Experimental verification revealed that the above equation is an over estimate.

Merchant later modified this equation and gave another equation  $2\phi + \beta - \alpha = C$

Where  $C$  is the machining constant. Usually  $C \leq \frac{\pi}{2}$  depends upon the work materials.

According to Merchant,  $C$  is a property of work material unaffected by cutting conditions, but grain size and micro structure have an affect on  $C$ .

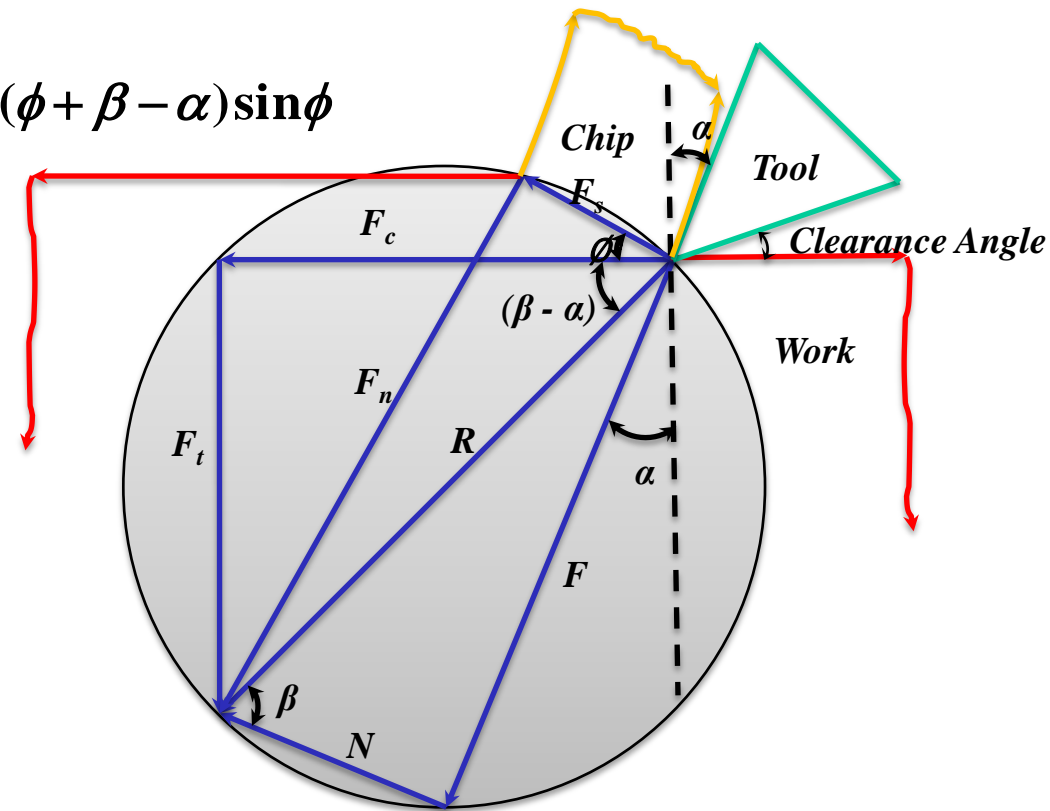

# Merchant's second solution (Modified Merchant's Theory)

Merchant attempted an alternative solution assuming that the effect of deformation and friction are reflected through a change of normal force  $F_n$ , acting in a direction perpendicular to the plane of shear. In turn the normal stress,  $\sigma_n$ , of the shear plane affects the shear stress,  $\tau_s$ , in the direction of shear.

It was assumed that  $\tau_s = \tau_0 + k\sigma_n$  this is commonly known as Bridgeman's relation and  $k$  is the slope of  $\tau_s - \sigma_n$  characteristic

$$\tau_s = \tau_0 + k\sigma_n \dots (1)$$

From the Merchant Circle diagram Relation

$$F_n = F_s \tan(\phi + \beta - \alpha)$$

Dividing by the area of the shear plane, we get

$$\sigma_n = \tau_s \tan(\phi + \beta - \alpha) \dots (2)$$

From equation (1) and (2), we get

$$\tau_s = \tau_0 + k\tau_s \tan(\phi + \beta - \alpha)$$

$$\Rightarrow \tau_s = \frac{\tau_0}{1 - k \tan(\phi + \beta - \alpha)} \dots (3)$$

$$\text{We Know, } \tau_s = \frac{F_c \sec(\beta - \alpha) \cos(\phi + \beta - \alpha) \sin \phi}{w \times t_0} \dots (4)$$

$$\text{From equation (3) and (4), we get } F_c = \frac{w \times t_0 \cos(\beta - \alpha)}{\cos(\phi + \beta - \alpha) \sin \phi [1 - k \tan(\phi + \beta - \alpha)]}$$

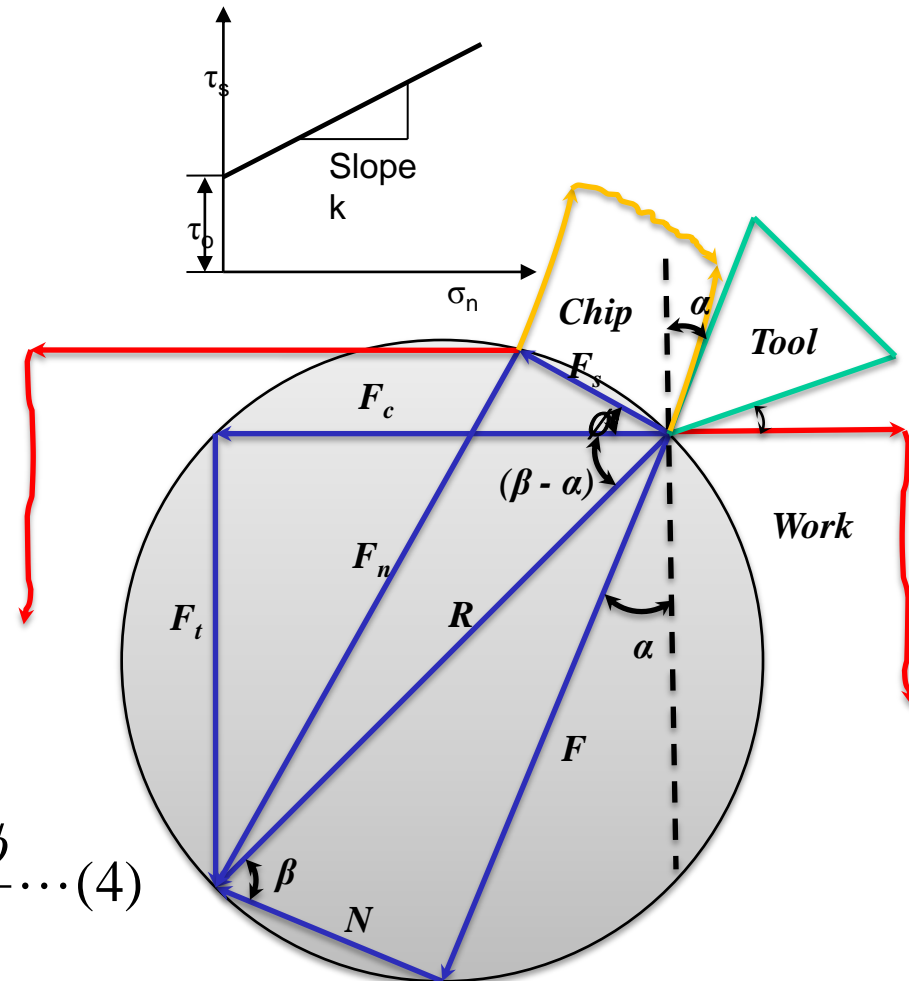



## Merchant's second solution (contd..)

From principle of minimum energy,  $F_c$  is minimum, when denominator is maximum.

$$\text{Therefore if } y = \cos(\phi + \beta - \alpha) \sin \phi [1 - k \tan(\phi + \beta - \alpha)]$$

$$\Rightarrow y = \cos(\phi + \beta - \alpha) \sin \phi - k \sin(\phi + \beta - \alpha) \sin \phi$$

$$\frac{dy}{d\phi} = 0$$

$$= \cos(\phi + \beta - \alpha) \cos \phi - \sin(\phi + \beta - \alpha) \sin \phi - k \sin(\phi + \beta - \alpha) \cos \phi - k \cos(\phi + \beta - \alpha) \sin \phi$$

$$\Rightarrow \cos(\phi + \beta - \alpha) \cos \phi - \sin(\phi + \beta - \alpha) \sin \phi$$

$$= k [\sin(\phi + \beta - \alpha) \cos \phi + \cos(\phi + \beta - \alpha) \sin \phi]$$

$$\Rightarrow \cos(2\phi + \beta - \alpha) = k \sin(2\phi + \beta - \alpha)$$

$$\Rightarrow \cot(2\phi + \beta - \alpha) = k$$

$$\Rightarrow 2\phi + \beta - \alpha = \cot^{-1} k = C$$

$$\Rightarrow 2\phi + \beta - \alpha = C$$

where C is machining constant

# Stress and Strain acting on the chip

$$\text{Mean shear stress } \tau_s = \frac{F_s}{A_s}$$

$$\text{Mean normal stress } \sigma_s = \frac{F_n}{A_s}$$

The shear strain be  $\gamma$ .

Considering no loss of work during shearing

We Know,

Work done in shearing unit volume of the metal = shear stress  $\times$  shear strain

$$\Rightarrow \frac{F_s \times v_s}{t_0 \times w \times v_c} = \tau_s \times \gamma$$

$$\Rightarrow \gamma = \frac{F_s \times v_s}{\tau_s \times t_0 \times w \times v_c}$$

$$\Rightarrow \gamma = \frac{F_s \times v_s}{\frac{F_s}{A_s} \times t_0 \times w \times v_c}$$

$$\Rightarrow \gamma = \frac{F_s \times v_s}{\frac{F_s}{\frac{t_0 \times w}{\sin \phi}} \times t_0 \times w \times v_c}$$

$$\Rightarrow \gamma = \frac{v_s}{v_c} \times \frac{1}{\sin \phi}$$

$$\text{But } \frac{v_s}{v_c} = \frac{\cos \alpha}{\cos(\phi - \alpha)}, \text{ therefore}$$

$$\Rightarrow \gamma = \frac{\cos \alpha}{\cos(\phi - \alpha) \sin \phi}$$

# Stress and Strain acting on the chip

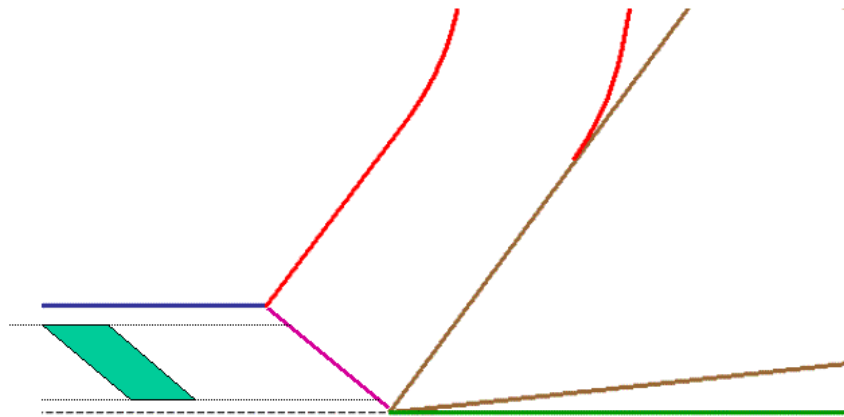

Work

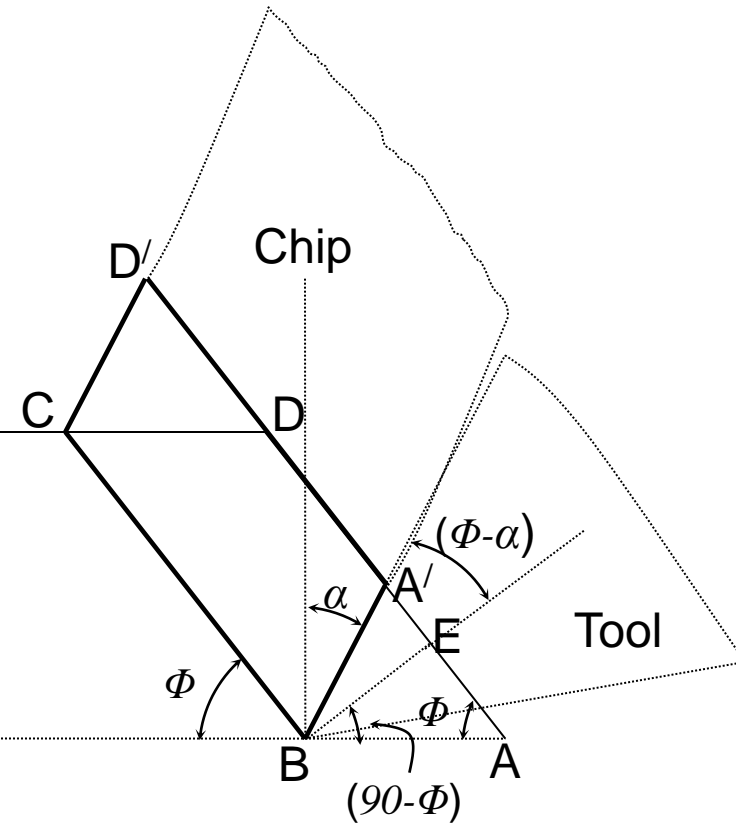

Shearing of chip

# Stress and Strain acting on the chip (contd..)

The magnitude of shear strain  $\gamma$

$$\approx \tan \angle ABE + \tan \angle A'BE = \frac{AE}{BE} + \frac{A'E}{BE}$$

$$\Rightarrow \gamma = \frac{AE}{BE} + \frac{A'E}{BE}$$

$$\angle A'BE = 90 - (90 - \phi) - \alpha = \phi - \alpha$$

$$\Rightarrow \gamma = \cot \phi + \tan(\phi - \alpha)$$

$$\Rightarrow \gamma = \frac{\cos \phi}{\sin \phi} + \frac{\sin(\phi - \alpha)}{\cos(\phi - \alpha)}$$

$$\Rightarrow \gamma = \frac{\cos \phi \cos(\phi - \alpha) + \sin \phi \sin(\phi - \alpha)}{\sin \phi \cos(\phi - \alpha)}$$

$$\Rightarrow \gamma = \frac{\cos(\phi - \phi + \alpha)}{\sin \phi \cos(\phi - \alpha)}$$

$$\Rightarrow \gamma = \frac{\cos \alpha}{\sin \phi \cos(\phi - \alpha)}$$

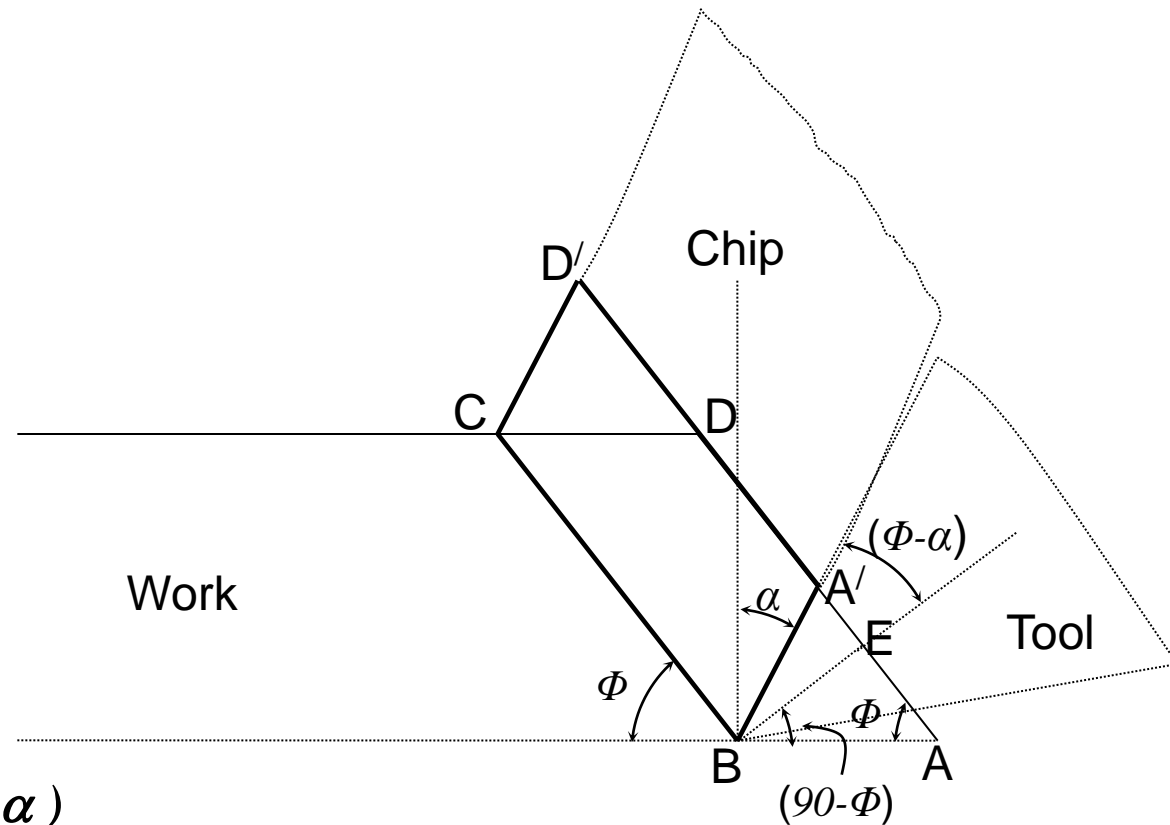

Shearing of chip

# Thrust Force vs Rake Angle

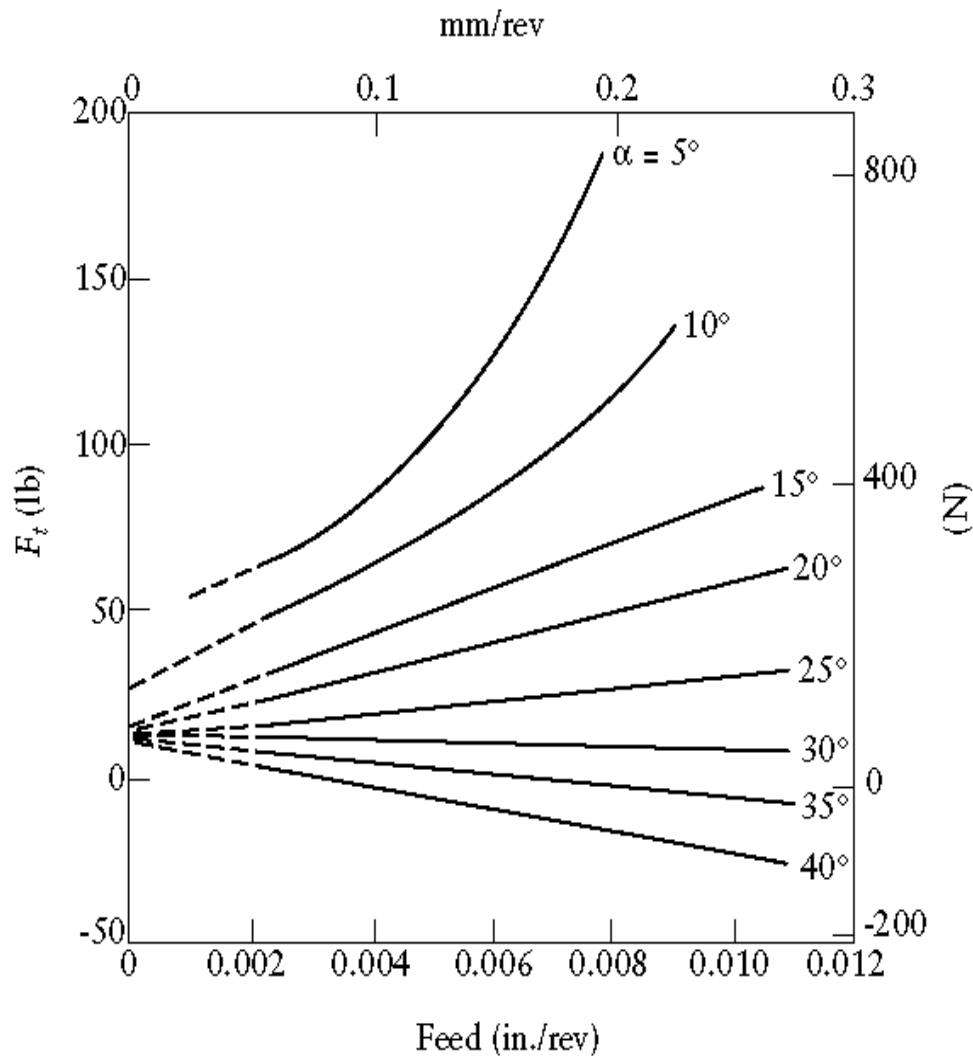

FIGURE Thrust force as a function of rake angle and feed in orthogonal cutting of AISI 1112 cold-rolled steel. Note that at high rake angles, the thrust force is negative. A negative thrust force has important implications in the design of machine tools and in controlling the stability of the cutting processes. *Source:* After S. Kobayashi and E. G. Thomsen.

Figure from: “Manufacturing Processes for Engineering Materials”, 4<sup>th</sup> edition, Kalpakjian, Schmid, Prentice Hall 2003

# Shear and Normal Force

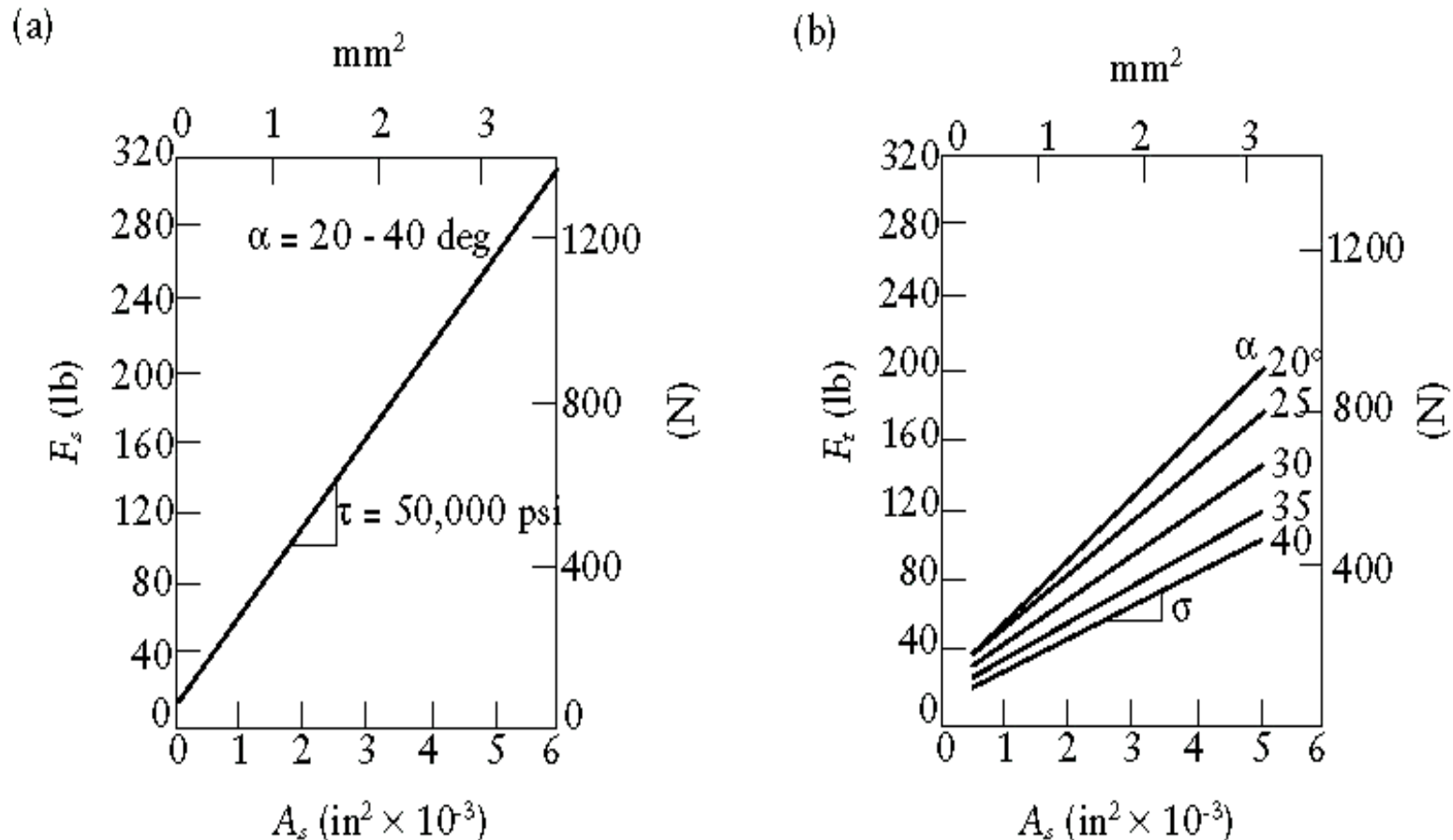

FIGURE Shear force and normal force as a function of the area of the shear plane and the rake angle for 85-15 brass. Note that the shear stress in the shear plane is constant, regardless of the magnitude of the normal stress. Thus, normal stress has no effect on the shear flow stress of the material. *Source:* After S. Kobayashi and E. G. Thomsen, *J. Eng. Ind.*, 81: 251-262, 1959.

Figure from: “Manufacturing Processes for Engineering Materials”, 4<sup>th</sup> edition, Kalpakjian, Schmid, Prentice Hall 2003



# Shear and Normal Force

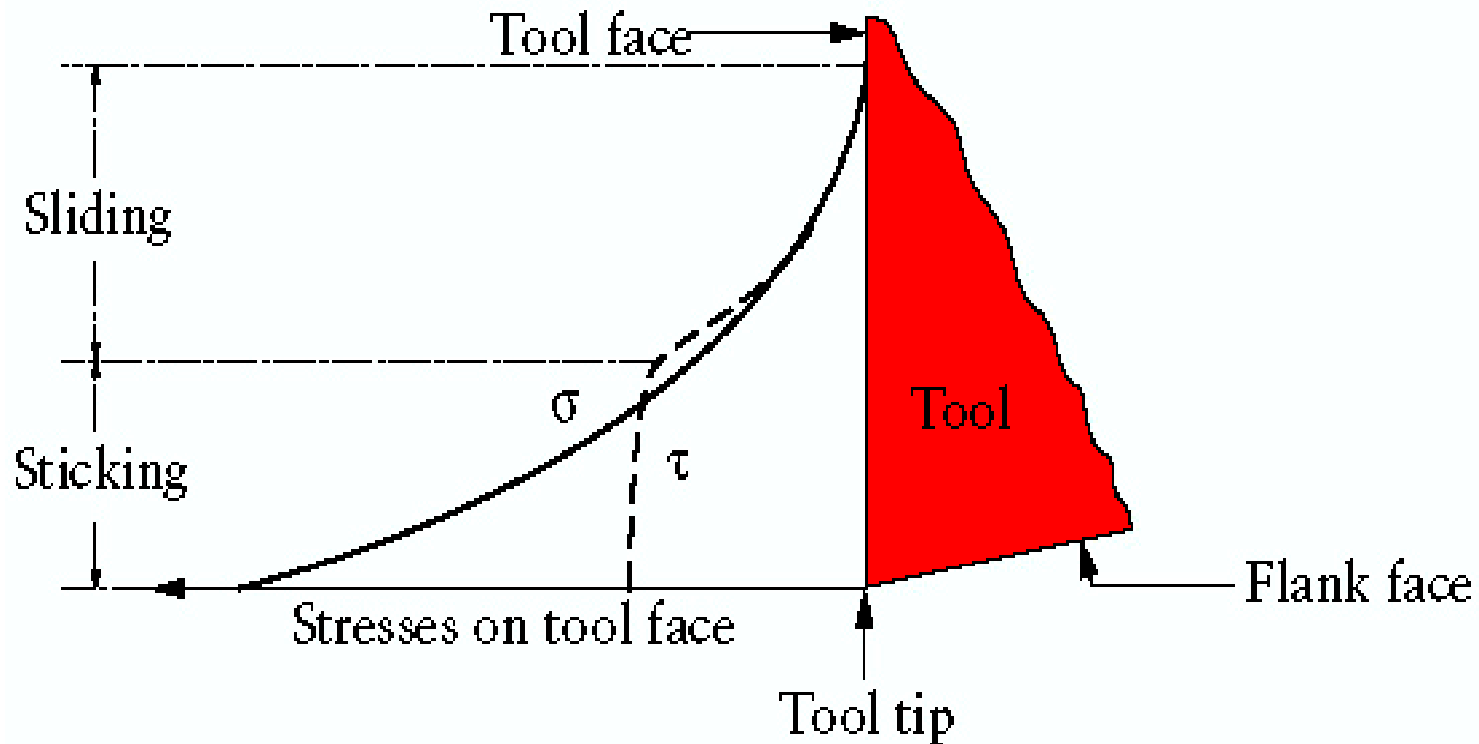

FIGURE: Schematic illustration of the distribution of normal and shear stresses at the tool-chip interface (rake face). Note that, whereas the normal stress increases continuously toward the tip of the tool, the shear stress reaches a maximum and remains at that value (a phenomenon known as *sticking*).

Figure from: “Manufacturing Processes for Engineering Materials”, 4<sup>th</sup> edition, Kalpakjian, Schmid, Prentice Hall 2003

# Temperature Distribution in the Cutting Zone

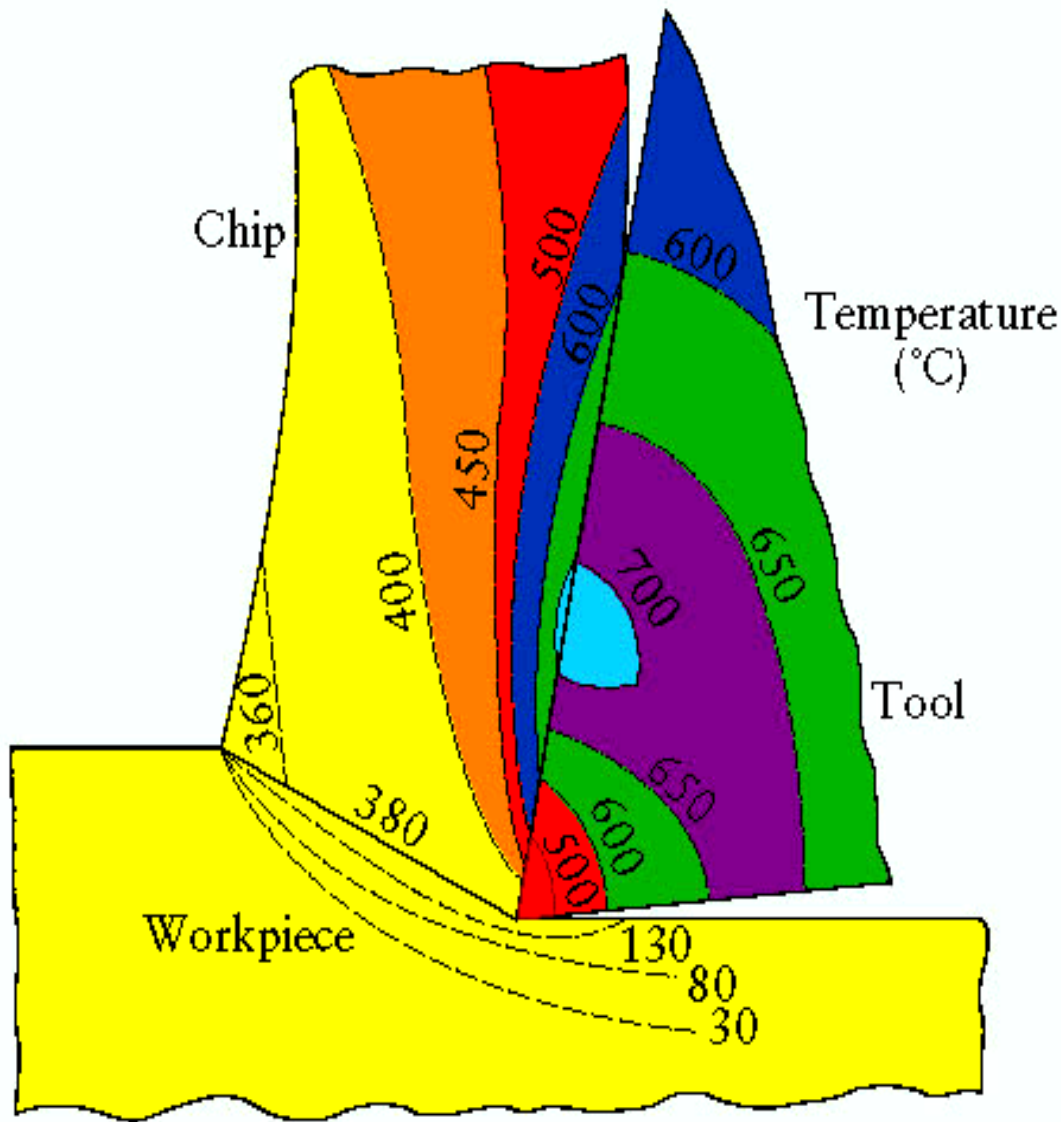

FIGURE: Typical temperature distribution in the cutting zone. Note that the maximum temperature is about halfway up the face of the tool and that there is a steep temperature gradient across the thickness of the chip. Some chips may become red hot, causing safety hazards to the operator and thus necessitating the use of safety guards. *Source:* After G. Vieregge.

Figure from: “Manufacturing Processes for Engineering Materials”, 4<sup>th</sup> edition, Kalpakjian, Schmid, Prentice Hall 2003

# Temperature Distribution in Turning

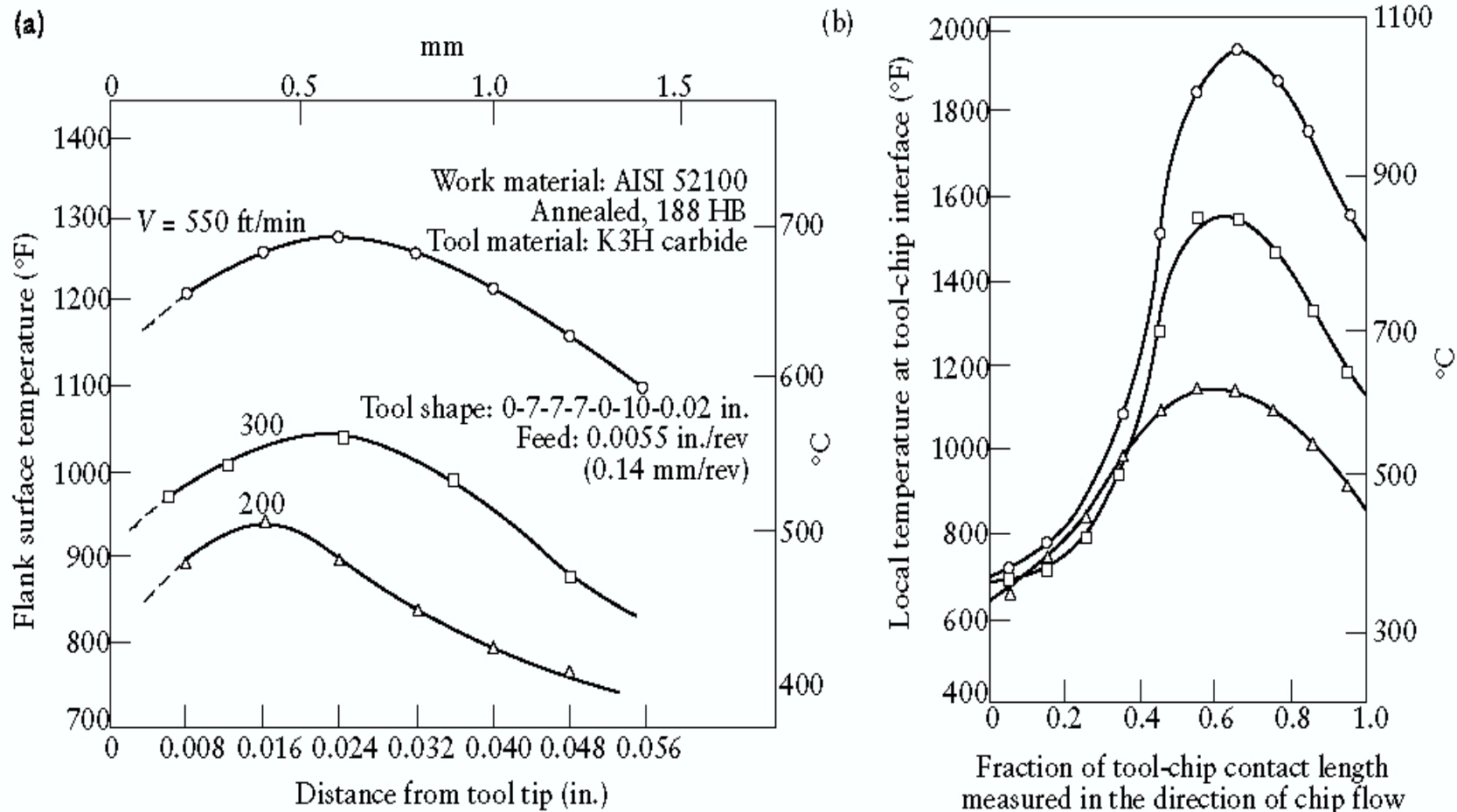

FIGURE : Temperature distribution in turning: (a) flank temperature for tool shape (b) temperature of the tool-chip interface. Note that the rake face temperature is higher than that at the flank surface. *Source:* After B. T. Chao and K. J. Trigger.

Figure from: “Manufacturing Processes for Engineering Materials”, 4<sup>th</sup> edition, Kalpakjian, Schmid, Prentice Hall 2003

# Hardness Distribution in the Cutting Zone

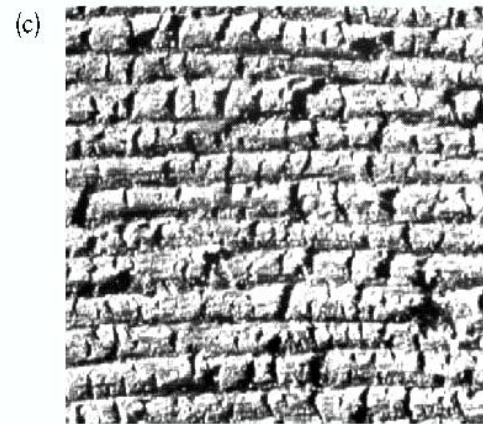
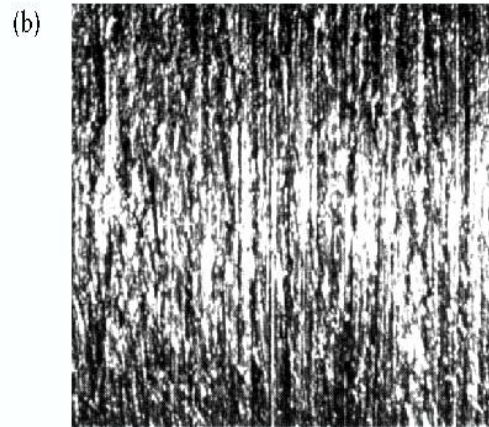
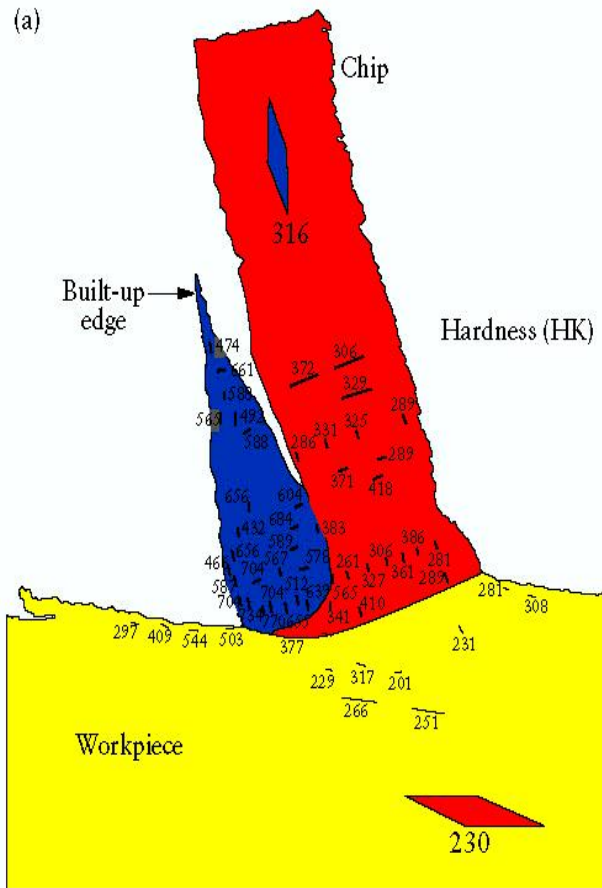

FIGURE : (a) Hardness distribution in the cutting zone for 3115 steel. Note that some regions in the built-up edge are as much as three times harder than the bulk metal. (b) Surface finish in turning 5130 steel with a built-up edge. (c) Surface finish on 1018 steel in face milling. Magnifications: 15X. *Source:* Courtesy of Institute of Advanced Manufacturing Sciences, Inc.

Figure from: “ Manufacturing Processes for Engineering Materials”, 4<sup>th</sup> edition, Kalpakjian, Schmid, Prentice Hall 2003

# References

1. **Kalpakjian, Schmid**, Manufacturing Processes for Engineering Materials, *4th edition*, Prentice Hall 2003
2. **DeGarmo, E. P., J. T. Black, and R. A. Kohser**, Materials and processes in Manufacturing, *PHI*.
3. **P.N. Rao**, Manufacturing Technology – Metal Cutting and Machine Tools, *TMH*.
4. **George Schneider, Jr. CMfgE**, Cutting Tool Applications
5. **Amstead, B. H., P. F. Ostwald, and M. L. Begeman**, Manufacturing Processes, 8th ed., *Wiley, New York*, 1988.
6. **Amitabha Battacharya**, Metal Cutting Theory and Practice
7. **Shaw, M. C.**, Metal Cutting Principles, *Oxford University Press, Oxford*, 1984.
8. **Schey, J. A.**, Introduction to Manufacturing Processes, *McGraw-Hill, New York*, 1977.
9. **Lindberg, R. A.**, *Processes and Materials of Manufacture*,
10. **William J Patton**, Machine tool Operations, *Reston publishing company*
11. **O W Boston**, Metal Processing, 2nd edition 1951, *John Wiley and Sons*
12. **B.S.Raghuwanshi**, A course in Workshop Technology-*Dhanpat Rai & Sons*.
13. **Hajra Choudhury**, Elements of Workshop Technology–Vol.-II, *Media Promoters and Publishers*.
14. **O P Khanna**, Production Technology-(Vol. II)
15. **R K Jain**, Production Technology
16. **HMT**, Production Technology, *HMT*